

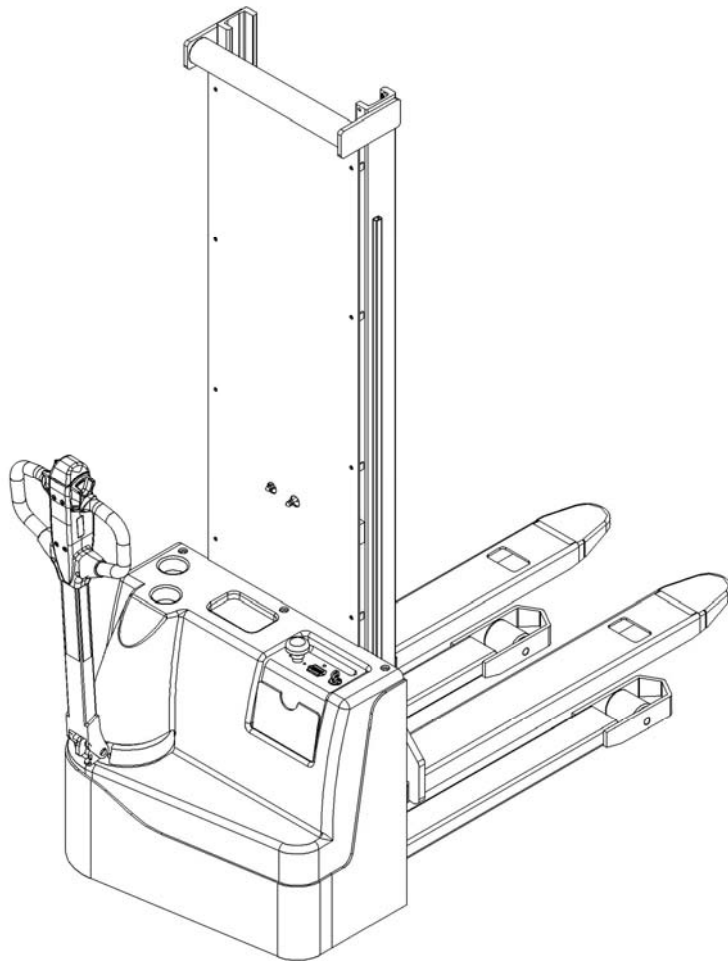

INSTRUCTION HANDBOOK Electric Stacker ECL 10



WARNING



Do not use the electric truck before reading and understanding these operating instructions.

NOTE:

- **Please check the designation of your present type at the last page of this document as well as on the ID-plate.**
- **Keep for future reference.**

FOREWORD

Before operating the electric stacker, read this ORIGINAL INSTRUCTION HANDBOOK carefully and understand the usage of the truck completely. Improper operation could create danger.

This handbook describes the usage of different electric stackers. When operating and servicing the truck, make sure, that it applies to your type.

 **Chapter 11 describes specialized stipulations and regulations for the American market. Follow these instructions and stipulations if you operate the truck within the American market!**

Keep this handbook for future reference. If this or the warning/ caution labels are damaged or got lost, please contact your local dealer for replacement.

This truck complies with the requirements according to EN 3691-1 (Industrial trucks- safety requirements and verification, part 1), EN 12895 (Industrial trucks- electromagnetic compatibility), EN 12053 (Safety of industrial trucks- test methods for measuring noise emissions), EN 1175 (Industrial truck safety – electrical requirements), assumed the truck is used according to the described purpose.

ATTENTION:

- Environmentally hazardous waste, such as batteries, oil and electronics, will have a negative effect on the environment, or health, if handled incorrectly.
- The waste packages should be sorted and put into solid dustbins according to the materials and be collected disposal by local special environment protection bureau. To avoid pollution, it's forbidden to throw away the wastes randomly.
- To avoid leaking during the use of the products, the user should prepare some absorbable materials (scraps of wooden or dry duster cloth) to absorb the leaking oil in time. To avoid second pollution to the environment, the used absorbable materials should be handed in to special departments in terms of local authorities.
- Our products are subject to ongoing developments. Because this handbook is only for the purpose of operating /servicing the stacker, therefore please have understanding, that there is no guarantee out of particular features out of this handbook.

 **NOTE: On this manual, the left sign means warning and danger, which can lead to death or serious injury if not followed.**

Copyright

The copyright remains with the company, mentioned on the CE- certificate at the end of this document or, if sold within the USA, with the company, mentioned on the company sticker.

TABLE OF CONTENTS

1. CORRECT APPLICATION	3
2. DESCRIPTION OF THE STACKER	4
a. Overview of the main components	4
b. Main technical data	5
c. Description of the safety devices and warning labels (Europe and other, excepting USA)	7
d. Identification plate	7
3. WARNINGS, RESIDUAL RISK AND SAFETY INSTRUCTIONS	8
4. COMMISSIONING, TRANSPORTING, DECOMMISSIONING	8
a. Commissioning	8
b. Lifting/ transportation	9
c. Decommissioning	10
3. DAILY INSPECTION	10
4. OPERATING INSTRUCTIONS	10
a. Parking	11
b. Residual lift diagram	11
c. Lifting	11
d. Lowering	11
e. Travelling	12
f. Steering	12
g. Braking	12
h. Malfunctions	13
i. Emergency	13
5. BATTERY CHARGING AND REPLACEMENT	13
a. Replacement	14
b. Battery Indicator	14
c. Charging	14
6. REGULAR MAINTENANCE	15
a. Maintenance checklist	15
b. Lubricating points	17
c. Check and refill hydraulic oil	17
d. Checking electrical fuses	17
e. Removing, reattaching guarding	18
7. TROUBLE SHOOTING	18
8. WIRING/ CIRCUIT DIAGRAM	20
a. Electrical circuit diagram	20
b. Hydraulic circuit	21
9. SPECIALIZED STIPULATIONS FOR THE US- AMERICAN MARKET	22
a. Foreword/ Compliance	22
b. Description warning labels (only US- market)	23
10. DECLARATION OF CONFORMITY (valid, if sold within the EU)	25

1. CORRECT APPLICATION

It is only allowed to use this electric stacker according to this instruction handbook.

The in this handbook described trucks are self propelled pedestrian controlled electric power stacker, with electrically operated lifting function. The trucks are designed for stacking operations in dedicated racking by lifting and lowering the palletized load up to the desired lifting height.

A wrong usage can cause human injuries or can damage equipment.

The operator/ the operating company has to ensure the correct usage and has to ensure, that this truck is used only by staff, which is trained and authorized to use this truck.

The truck has to be used on substantially firm, smooth, prepared, level and adequate surfaces. The truck is intended to be used for indoor applications with ambient temperatures between +5°C and + 40°C and for light duty applications without crossing permanent obstacles or potholes. Operating on ramps is not allowed. While operating, the load must be placed approximately on the longitudinal centre plane of the stacker. Lifting or transporting people is forbidden. If travelling the load must be lowered to the lifting point.

It is not allowed to use this truck on tail lifts or loading ramps.

The capacity is marked on the load diagram as well on the Identification plate. The operator has to consider the warnings and safety instructions. Operating lighting must be minimum 50 Lux.

Modification

No modifications or alterations to this truck which may affect, for example, capacity, stability or safety requirements of the truck, shall be made without the prior written approval of the original truck manufacturer, its authorized representative, or a successor thereof. This includes changes affecting, for example braking, steering, visibility and the addition of removable attachments. When the manufacturer or its successor approve a modification or alteration, they shall also make and approve appropriate changes to capacity plate, decals, tags and operation and maintenance handbooks.

By not observing these instructions, the warranty becomes void.

2. DESCRIPTION OF THE STACKER

a. Overview of the main components

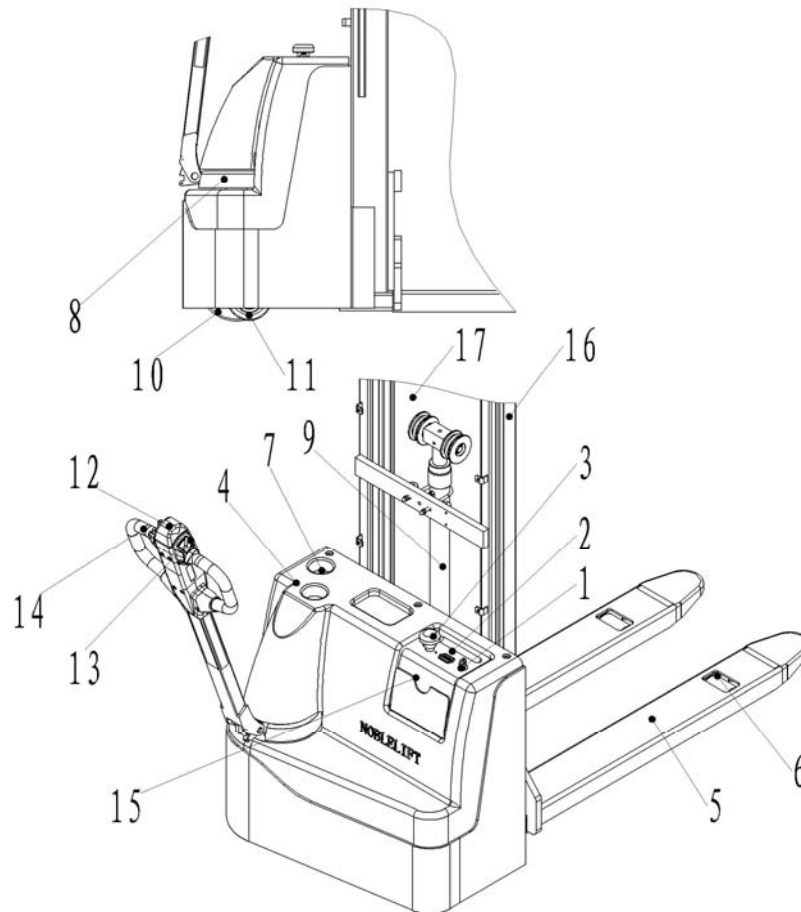

Fig. 1: Overview main components

- | | | | |
|---|---|----|---------------------------------|
| 1 | Key switch | 10 | Drive wheel |
| 2 | Discharge indicator and charging indicating LED | 11 | Castors |
| 3 | Emergency button | 12 | Safety (belly) button |
| 4 | Main cover | 13 | Accelerator (butterfly- switch) |
| 5 | Forks | 14 | Multifunction tiller |
| 6 | Load wheels | 15 | Front panel |
| 7 | Charging cable | 16 | Chassis with mast |
| 8 | Drive motor cover | 17 | Protective screen |
| 9 | Hydraulic cylinder | | |

b. Main technical data

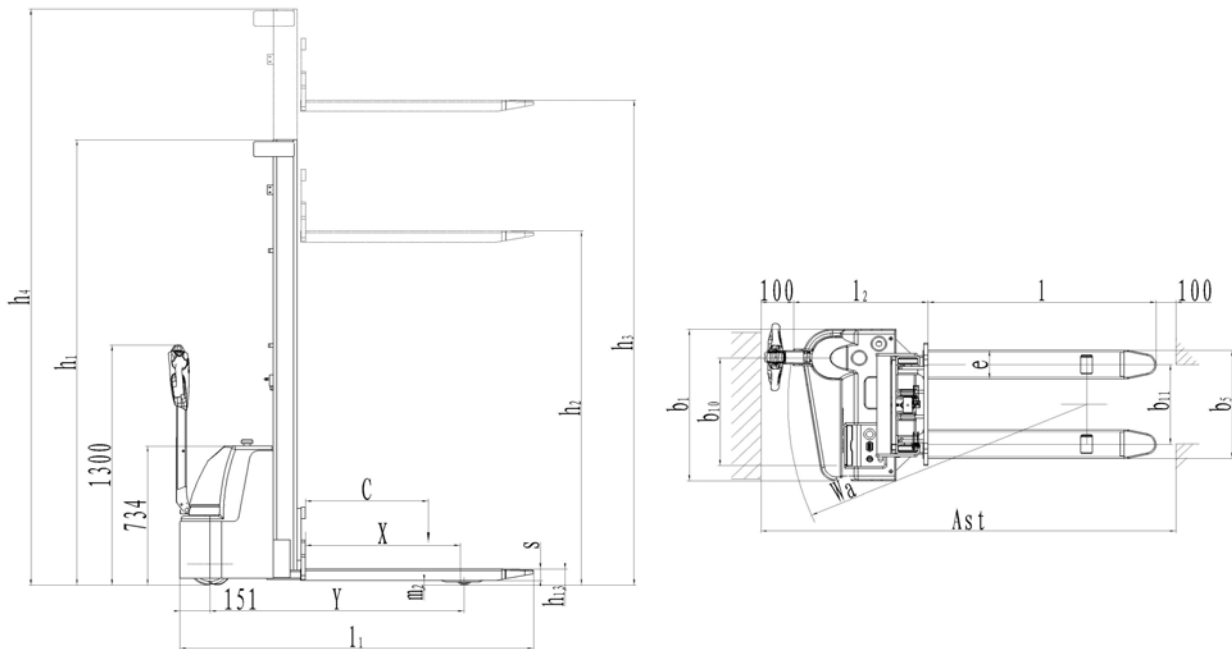

Fig. 2: Technical data

Table 1: Main technical data for standard version

Technical data sheet for industrial trucks acc. to VDI 2198					
Distinguishing mark	1.2	Manufacturer's type designation		ECL 1029	ECL 1029 M
	1.3	Drive		Battery	
	1.4	Operator type		Pedestrian	
	1.5	Load Capacity / rated load	Q (t)	1.0	
	1.6	Load centre distance	C (mm)	600	
	1.8	Load distance ,centre of drive axle to fork	X (mm)	800	733
	1.9	Wheelbase	Y (mm)	1281	
Weight	2.1	Service weight	kg	510	756
	2.2	Axle loading, laden front/rear	kg	580/930	786/970
	2.3	Axle loading, unladen front/rear	kg	385/125	530/226
Tyres, Chassis	3.1	Tires		Polyurethane (PU)	
	3.2	Tire size, front	Ø x w (mm)	Ø220 × 70	
	3.3	Tire size, rear	Ø x w (mm)	Ø80 × 93	
	3.4	Additional wheels(dimensions)	Ø x w (mm)	Ø124 × 60	
	3.5	Wheels, number front/rear(x=driven wheels)		1x+1 / 2	
	3.6	Tread, front	b ₁₀ (mm)	529	
	3.7	Tread, rear	b ₁₁ (mm)	420/ 535	1130 - 1500
Dimensions	4.2	Lowered mast height	h ₁ (mm)	1950	1935
	4.3	Free Lift height	h ₂ (mm)	70	70
	4.4	Lift	h ₃ (mm)	2840	2840
	4.5	Extended mast height	h ₄ (mm)	3325	3420
	4.9	Height of tiller in drive position min./ max.	h ₁₄ (mm)	785/ 1300	
	4.15	Height, lowered	h ₁₃ (mm)	85	40

	4.19	Overall length	l_1 (mm)	1800	1638
	4.20	Length to face of forks	l_2 (mm)	632	700
	4.21	Overall width	b_1 (mm)	800	1250
	4.22	Fork dimensions	s/e/l (mm)	60/150/1150	35/100/1150 ¹⁾
	4.25	Distance between fork- arms	b_5 (mm)	570/ 685	282 - 800
	4.32	Ground clearance, centre of wheelbase	m_2 (mm)	29	25
	4.33	Aisle width for pallets 1000X1200 crossways	Ast (mm)	2318	2341
	4.34	Aisle width for pallets 800X1200 lengthways	Ast (mm)	2250	2300
	4.35	Turning radius	Wa (mm)	1485	
Performance data	5.1	Travel speed, laden/ unladen	km/h	4.3 / 4.5	
	5.2	Lift speed, laden/ unladen	m/s	0,11/ 0,16	
	5.3	Lowering speed, laden/ unladen	m/s	0,13/ 0,11	
	5.8	Max. gradeability, laden/ unladen	%	5 / 10	
	5.10	Service brake		Electromagnetic	
Electric-motor	6.1	Drive motor rating S2 60min	kW	0.45	
	6.2	Lift motor rating at S3 7.5%	kW	2.2	
	6.3	Battery acc. to DIN 43531/ 35/ 36 A, B, C, no		no	
	6.4	Battery voltage, nominal capacity K5	V/Ah	2X 12/ 85 2)	
	6.5	Battery weight	kg	2X 25	
	6.6	Energy consumption acc. to VDI cycle	kWh/h	0.73	0.76
Additional data	8.1	Type of drive control		DC- Speed Control	
	8.4	sound level at driver`s ear acc. to EN 12053	dB(A)	< 70	

1) Optional: 35/ 100/ 950

2) Optional: 2x12V / 106 Ah

Other type data

1.2	Manufacturer`s type designation		ECL 1016	ECL 1020	ECL 1032	ECL 1035	ECL 1016 M	ECL 1020 M	ECL 1032M	ECL 1035M
1.8	Load distance ,centre of drive axle to fork	x(mm)	821		809		745		733	
2.1	Service weight	kg	430	450	525	540	676	696	771	786
2.2	Axle loading, laden front/rear	kg	550/880	560/890	590/935	600/940	736/940	756/940	796/975	406/980
2.3	Axle loading, unladen front/rear	kg	335/105	340/110	395/130	405/135	500/176	510/186	540/231	550/236
4.2	Lowered mast height	h_1 (mm)	1950	2350	2100	2250	1935	2335	2085	2235
4.3	Free Lift height	h_2 (mm)	1530	1930	70	70	1530	1930	70	70
4.4	Lift	h_3 (mm)	1530	1930	3140	3440	1530	1930	3140	3440
4.5	Extended mast height	h_4 (mm)	1950	2350	3625	3925	2120	2520	3720	4020
4.20	Length to face of forks	l_2 (mm)	620		632		688		700	
4.33	Aisle width for pallets 1000X1200 crossways	Ast (mm)	2312		2315		2336		2341	
4.34	Aisle width for pallets 800X1200 lengthways	Ast (mm)	2236		2245		2290		2300	
6.6	Energy consumption acc. to VDI cycle	kWh/h	0.68		0.73		0.71		0.76	

c. Description of the safety devices and warning labels (Europe and other, excepting USA)



For the USA –market, the description of the safety and warning labels is mentioned in chapter 11.

- A Crane hook label
- B Warning decal: Do not step under or on the forks
- C Residual lift capacity sticker
- D Sticker to read and follow these instructions
- E ‘No passengers’ decal
- F Identification plate (ID-plate)
- (3) Emergency button
- (12) Safety (belly) button

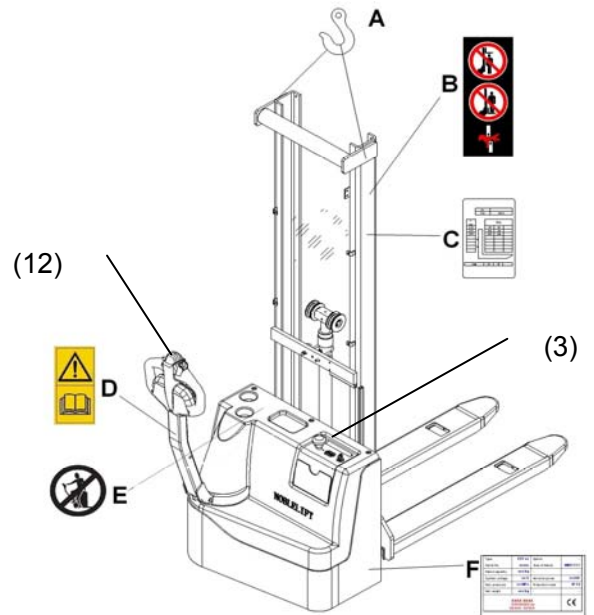

The truck has an emergency button(3) which stops all lifting-, lowering-, driving- functions and engages the failsafe electromagnetic brake when it is pushed.

Fig.3: Safety and warning labels

By pulling this button, the truck can be operated after the controller checked the functions. Before operating, insert the key and turn the switch (1) clockwise. To prevent against unauthorized access, turn the key anti-clockwise and remove it, if you not operate this truck. The truck is equipped with a safety (belly) button (12) which switches the driving function away from the operator, if the truck travels towards the operator and the tiller is activated in the tillers operating zone. Follow also the instructions given on the decals. Replace the decals if they are damaged or missing.

d. Identification plate

- 1 Designation, type
- 2 Serial number
- 3 Rated capacity in kg
- 4 Supply voltage in V
- 5 Own mass (self weight) in kg without battery
- 6 Name and address of manufacturer)
- 7 Battery weight minimum/ maximum
- 8 Nominal power in kW
- 9 Load center distance
- 10 Manufacturing data
- 11 Option

1	Type	xx●xx	Option	xx X xxx●	
2	Serial No.	●xxxx	Year of Manuf.	MM/YY●	11
3	Rated capacity	●xxxx kg	Load center distance	xxx mm	10
4	System voltage	● xx V	Nominal power	xx kW●	9
5	Net weight without battery	● xxx kg	Battery mass min/max	xxx / xxx kg	8
					7
6		● XXXX XXXX XXXXXXXX xx XXXXX / XXXXX		CE●	If sold to the EU, here the place of the CE marking

Fig. 4: Identification plate

WARNINGS, RESIDUAL RISK AND SAFETY INSTRUCTIONS



DO NOT

- Drive outside the stacking operation with a lifted load higher than the lifting point.
- Put foot or hand under or into the lifting mechanism.
- Allow other person than the operator to stand in front of or behind the truck when it is moving or lifting/lowering.
- Overload the truck.
- Put foot in front of the wheels, injury could result.
- Lift people. People could fall down and suffer severe injury.
- Push or pull loads.
- Use this truck on ramps.
- Use the truck without a removed protective screen (fig.1, pos. 17/ guarding).
- Side or end load. Load must be distributed evenly on the forks.
- Use the truck with unstable, unbalanced not stable load.
- Use truck without manufacturer's written consent.
- Supply on board charger with AC voltage other than 110V or 220V.

Watch difference in floor levels when driving. Load could fall down or the truck could get uncontrollable. Keep watching the condition of load. Stop operating the truck if load becomes unstable. Brake the truck and activate the emergency button (3) by pushing when sliding load on or off the truck. If the truck has any malfunctions, follow chapter 6. Practice maintenance work according to regular inspection. This truck is not designed to be water resistant. Use the truck under dry condition. Prolonged continuous operation might cause damage of the power pack. Stop operation if temperature of hydraulic oil is too high.



- When operating the truck, the operator has to wear safety shoes.
- The truck is intended to be used for indoor applications with ambient temperatures between +5°C and + 40°C.
- The operating lighting must be minimum 50 Lux.
- It is not allowed to use the truck on ramps.
- To prevent unintended sudden movements when not operating the truck (i.e. from another person, etc.) switch of the truck and remove the key.

4. COMMISSIONING, TRANSPORTING, DECOMMISSIONING

a. Commissioning

Table 2: Commissioning data

Type	ECL 1016	ECL 1020	ECL 1029	ECL 1016M	ECL 1020M	ECL 1029M
Commissioning weight [kg]	450	470	530	555	575	645
Version/ Lift [mm]	1600	2000	2900	1600	2000	2900
Type	ECL 1032	ECL 1035	ECL 1032M	ECL 1035M		
Commissioning weight [kg]	545	560	660	675		
Version/ Lift [mm]	3200	3500	3200	3500		

After receiving our new truck or for re-commissioning you have to do following before (firstly) operating the truck:

- Check if are all parts included and not damaged
- Eventually installation and charging the batteries (follow chapter 7)
- Do the work according to the daily inspections as well as functional checks.

b. Lifting/ transportation

For transporting, remove the load, lower the forks to the lowest position and fix the truck safe with dedicated lifting gear according to the following figures.

Lifting



USE DEDICATED CRANE AND LIFTING EQUIPMENT
DO NOT STAND UNDER THE SWAYING LOAD
DO NOT WALK INTO THE HAZARDOUS AREA DURING LIFTING

Park the truck securely and lash the truck according to the points identified in fig. 5

Lift the truck to its destination and place the truck securely before removing the lifting gear.

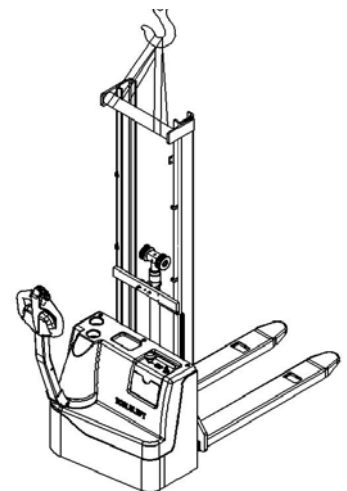

Fig.5: Lifting with a crane

Transportation



DURING TRANSPORTATION ON A LORRY OR TRUCK
ALWAYS FASTEN THE TRUCK SECURELY

Lower the forks and park the truck securely. Fasten the truck according to fig. 6 by fixing dedicated lashing belts at both sides each 2 pc of the trucks upper mast traverse and fasten the other side at the transporting truck.

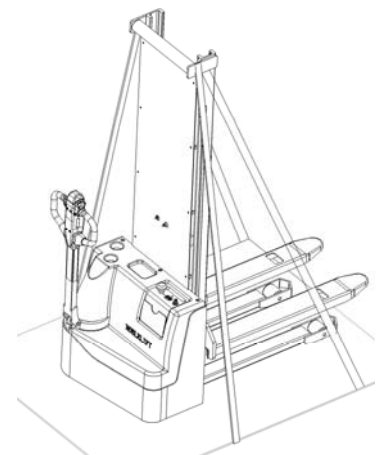

Fig. 6: Fixing points

C. Decommissioning

For storage, remove the load, lower the truck to the lowest position, grease all in this handbook mentioned greasing points (regular inspection), eventual protect the truck against corrosion and dust. Remove the batteries and jack the truck safety, so that there will be no flattening after storage.

For final decommissioning hand the truck to a designated recycling company. Oil, batteries and electric components must be recycled due to legal regulations.

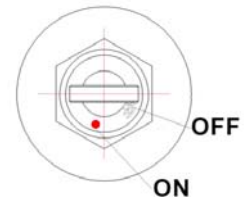

Fig.8: Key switch

3. DAILY INSPECTION

This chapter describes pre-shift checks before putting the truck into operation. Daily inspection is effective to find the malfunction or fault on this truck. Check the truck on the following points before operation.



Remove load from truck and lower the forks.
DO NOT USE THE TRUCK IF ANY MALFUNCTION IS FOUND.

- Check for scratches, deformation or cracks.
- Check if there is any oil leakage from the cylinder._
- Check the vertical creep of the truck.
- Check the chain and rollers for damages or corrosion.
- Check the smooth movement of the wheels.
- Check the function of the emergency brake by activating the emergency button.
- Check, the tiller arm- switch braking function
- Check the lifting and lowering functions by operating the buttons.
- Check if the protective screen has no damages and that is correctly assembled.
- Check the audio warning signal.
- Check if all bolts and nuts are tightened firmly.
- Check the function of the key switch.
- Check the speed limitation switch.
- Visual check if there are any broken hoses or broken electric wires.
- If supplied with a backrest extension, check it for damages and correct assembling.

4. OPERATING INSTRUCTIONS



BEFORE OPERATING THIS TRUCK, PLEASE FOLLOW THE WARNINGS AND SAFETY INSTRUCTIONS (CHAPTER 3).

BEFORE OPERATING THIS TRUCK, ENSURE THAT THE LOAD OR OTHER EQUIPMENT NOT CAUSES INSUFFICIENT VISIBILITY!

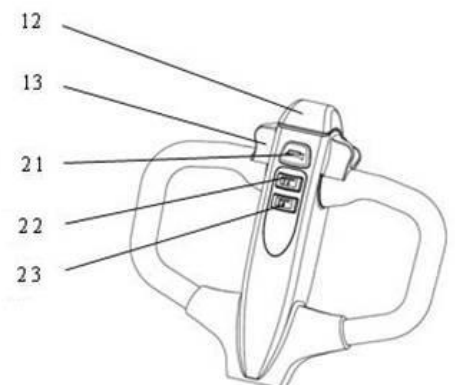

Fig.7: Tiller operating controls

Make sure, that the load is palletized and stable and that the daily inspection is carried out. For starting, insert the key and turn it clockwise to the “ON”- position. The key can be used only used on pedestrian controlled power stacker. Eventually before inserting the key, the emergency button must be pulled carefully.

Press the horn button (21) to activate the audible warning signal.

a. Parking



DO NOT PARK THE TRUCK ON INCLINED SURFACES

The truck is equipped with an electromagnetic failsafe stopping and parking brake. Always lower the forks fully and drive the truck to a safe area. Turn the key anti-clockwise to the “Off” – position and remove the key.

b. Residual lift diagram

The residual lift diagram indicates the maximum capacity Q [kg] for a given load centre c [mm] and the corresponding lift height H [mm] for the truck with horizontal load.

The white markings on the mast indicate if the specific lifting limits reached.

For instance with a load centre of gravity distance c of 600 mm and a maximum lift height H of 3500 mm, the max. capacity Q is 600 kg.

No.	ECL10	
Type	ECL10	
h_3 (mm)	Q (kg)	
3500	600	500
3200	800	600
2500	1000	800
2000	1000	1000
c (mm)	600	700

Fig. 9: Residual lift diagram

c. Lifting **DO NOT OVERLOAD THE TRUCK! THE MAXIMUM CAPACITY IS**



1000 kg.

LIFT ONLY CAPACITIES ACCORDING TO THE RESIDUAL LIFT DIAGRAM.

Travel with the lowered forks fully underneath the pallet and press the lifting button (fig. 7, 22) until you reached the desired lifting height.

d. Lowering

If the forks are in the racking, firstly travel out of the racking carefully with or without the pallet.

Press the lowering button (fig. 7, 23) carefully.

Lower the load until the forks are clear of the pallet, then drive the truck carefully out of the load unit.

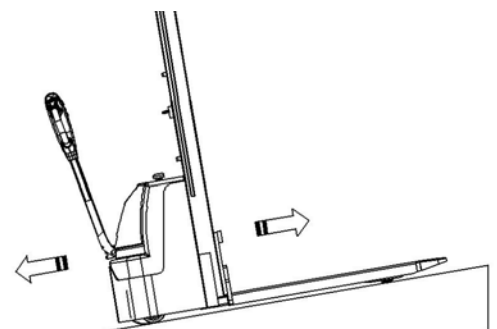

Fig.10: Load facing uphill

e. Travelling



TRAVEL ON INCLINES ONLY WITH THE LOAD FACING UPHILL.
DO NOT TRAVEL ON INCLINES MORE THAN SPECIFIED WITH THE TECHNICAL DATA.

TRAVELLING IS ONLY ALLOWED IF THE FORKS ARE LOWERED DOWN TO THE LIFTING POINT (<300MM).

After starting the truck by turning the inserted key to the "ON"- position (fig. 8; and eventually by pulling the emergency button carefully), move the tiller to the operating zone ('F', fig.11).

Turn the accelerator button to the desired direction forward 'Fw.' Or backwards 'Bw.'(fig. 11).

Control the travelling speed by moving the accelerator button (13) carefully until you reached the desired speed.

If you move the accelerator button back to the neutral position, the controller decelerates the truck until the truck stops. If the truck stopped, the parking brake will be engaged.

Drive carefully the truck to the destination. Watch the route conditions and adjust the travelling speed with the accelerator- button.

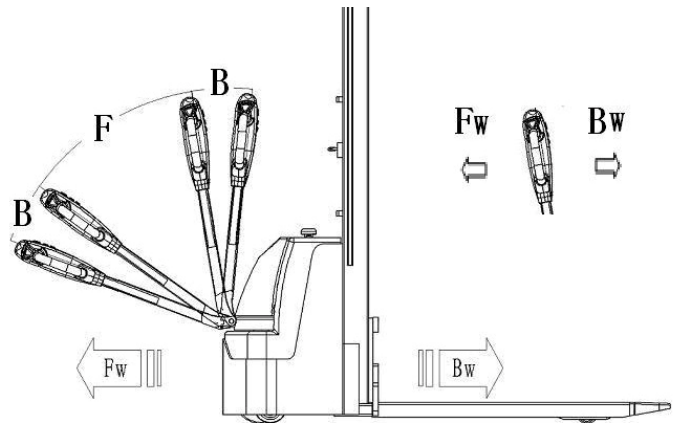

Fig.11: Operating direction

f. Steering

You steer the truck by moving the tiller to the left or right side.

g. Braking



THE BRAKING PERFORMANCE DEPENDS ONT THE TRACK CONDITONS AND THE LOAD CONDITONS OF THE TRUCK

The braking function can be activated on several ways:

- By moving the accelerator button (13) back to the initial '0' position or by releasing the button, the regenerative braking is activated. The truck brakes until it stops.
- By moving the accelerator button (13) from one driving direction directly to the opposite direction, the truck brakes regenerative until it starts travelling into the opposite direction.
- The truck brakes, if the tiller is moved up or down to the braking zones ('B'). If the tiller is released, the tiller moves automatically up to the upper baking zone ('B'). The truck brakes until it stops.
- The safety (belly) button (12) prevents the operator from being crushed. If this

button is activated, the truck decelerates and/ or starts travelling into the backwards direction ('Bw.') for a short distance and stops. Please consider, that this button also operates, if the truck is not travelling and the tiller is in the operating zone.

h. Malfunctions

If there are any malfunctions or the truck is inoperative, please stop using the truck and activate the emergency button (3) by pushing it. If possible, park the truck on a safe area, turn the key switch (1) anti- clockwise and remove the key.

Inform immediately the manager and, or call your service. If necessary, tow the truck out of the operating area by using dedicated lifting equipment.

i. Emergency

In emergencies, push the emergency button (3). All electrical functions will be stopped. Keep safe distance.

5. BATTERY CHARGING AND REPLACEMENT



- Only qualified personnel are allowed to service or charge the batteries. The instructions of this handbook and from the battery- manufacturer must be observed.
- These batteries are maintenance free; re- filling is prohibited.
- Recycling of batteries undergoes national regulations. Please follow these regulations.
- By handling batteries, open fire is prohibited, gases could cause explosion!
- In the area of battery charging neither burning materials nor burning liquids are allowed. Smoking is prohibited and the area must be ventilated.
- Park the truck securely before starting charging or installing/changing the batteries
- Before finishing the maintenance work, make sure, that all cables are connected correctly and that there are no disturbing towards other components of the truck.

The truck is equipped with following sealed liquid acid batteries:

- 2 pc 12V/ 85Ah(C5)
- Optional: 2 pc 12V/ 106Ah



IT IS ONLY ALLOWED TO USE SEALED LIQUID ACID BATTERIES.

THE WEIGHT OF THE BATTERIES HAS AN INFLUENCE TO THE TRUCKS OPERATING BEHAVIOR.

PLEASE CONSIDER THE MAXIMUM OPERATING TEMPERATURE OF THE BATTERIES.

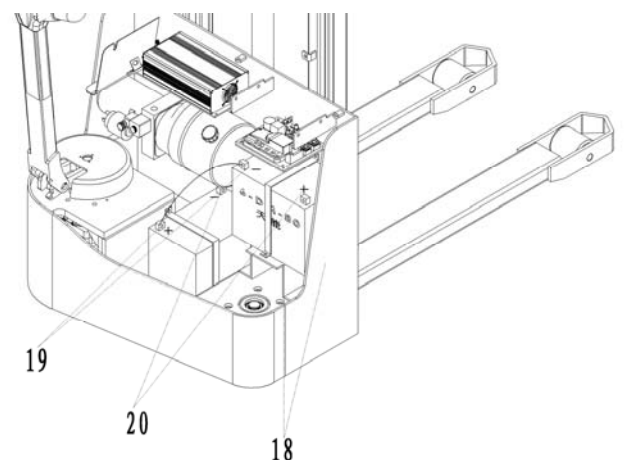

Fig. 12: battery replacement

a. Replacement

Park the truck securely and switch off the stacker with the key (1) and activate the emergency button (3). Unbolt the 2 screws on the main cover and remove the cover. Unbolt the screws of the negative terminals (indicated with '-') firstly, then unbolt the screws of the positive terminals (indicated with '+') and put the cables aside.

Unbolt the batteries fixing bars and remove these (fig. 13). Remove the batteries carefully by observing not to hit the upper electrical instruments board or the upside oil tank. The installation is in the reverse order of the removal. Please connect the positive terminals firstly. Otherwise the truck could be damaged.

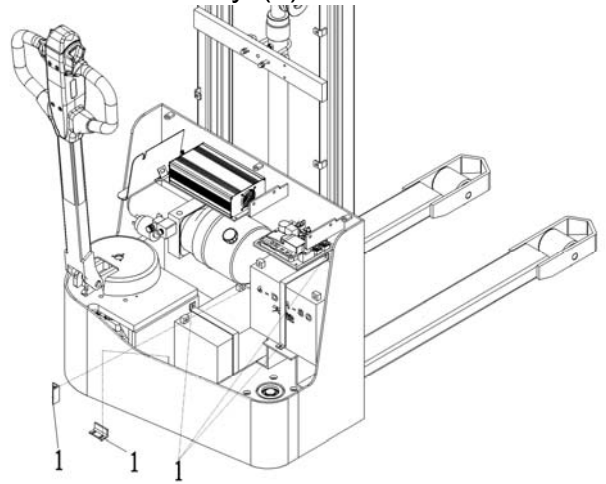
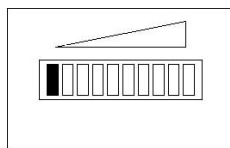

Fig. 13: Preparation to replace the batteries

b. Battery Indicator

The discharge status is indicated by ten red LED segments.



Battery discharged

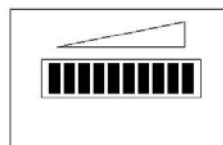

Battery full charged

Fig.14: Battery discharge indicator

Only when the battery is properly charged, the most right LED lit. As the battery's state-of-charge decreases, successive LEDs light up, only one on at a time. The 2nd from left LED flashes, indicating "energy reserve" (70% depth of discharge). The 2 most left LEDs alternately flash, indicating "empty" (80% depth of discharge).

c. Charging



- The attached automatic charger is only available for the optional voltage of 110V or 220V as referred.
- The room, where you are charging must be ventilated.
- The exactly charge status can be only checked from the discharge indicator. To control the status, the charging must be interrupted and the truck must be started.

Park the truck at a dedicated secured area with a deidcated power supply.

Lower the forks and remove the load.

Switch the truck off and connect the main power connector (7) to the power supply.

The charger starts charging the battery.

Charging is finished until the charging LED (fig.14,15) produces permanent green light. The charger then goes into a floating mode to prevent the battery against damages. Following table shows the function of the LED-status:

Table 3: LED-Status

LED- signal	Function
Red	Battery discharged
Orange	Charging
Green	Fully charged

When charging is finished, disconnect the connector from the socket and place it in the designated pocket.

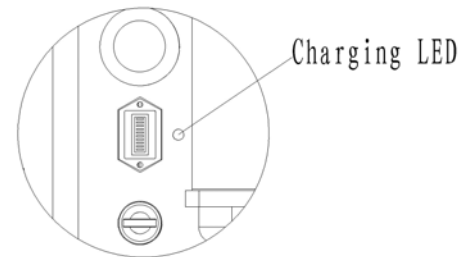
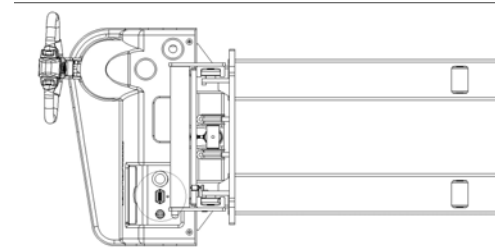

Fig. 15: LED- Status

6. REGULAR MAINTENANCE



- Only qualified and trained personnel are allowed to do maintenance on this truck.
 - Before maintaining, remove the load and lower the forks to the lowest position.
 - If you need to lift the truck, follow chapter 4 d by using designated lashing or jacking equipment. Before working, put safety devices (for instance designated lift jacks, wedges or wooden blocks) under the truck to protect against accidental lowering, movement or slipping.
 - Please pay attention by maintain the tiller arm. The gas pressure spring is pre-loaded by compression. Carelessness can cause injury.
 - Use approved and from your dealer released original spare parts.
 - Please consider that oil leakage of hydraulic fluid can cause failures and accidents.
 - It is allowed to adjust the pressure valve only from trained service technicians.
 - If you need to change the wheels, please follow the instructions above. The castors must be round and they should have no abnormal abrasion.
- Check the items emphasized maintenance checklist.

a. Maintenance checklist

Table 4: Maintenance checklist		Interval (Month)			
		1	3	6	12
	Hydraulic				
1	Check the hydraulic cylinder, piston for damage noise and leakage		•		
2	Check the hydraulic joints and hose for damage and leakage		•		
3	Inspect the hydraulic oil level, refill if necessary		•		
4	Refill the hydraulic oil (12 month or 1500 working hours)				•
5	Check and adjust the function of the pressure valve (1000 kg +0/ +10%)				•
	Mechanical system				
6	Inspect the forks for deformation and cracks		•		
7	Check the chassis for deformation and cracks		•		
8	Check if all screws are fixed		•		

9	Check mast and chain for corrosion, deformation or damages, replace if necessary	•			
10	Check the gearbox for noise and leakage		•		
11	Check the wheels for deformation and damages, replace if necessary		•		
12	Lubricate the steering bearing				•
13	Inspect and lubricate the pivot points		•		
14	Lubricate the grease nipples	•			
15	Replace the guarding and/or protective screen if it is damaged	•			
Electric system					
16	Inspect the electric wiring for damage		•		
17	Check the electric connections and terminals		•		
18	Test the Emergency switch function		•		
19	Check the electric drive motor for noise and damages		•		
20	Test the display		•		
21	Check if correct fuses are used, if necessary replace.		•		
22	Test the audio warning signal		•		
23	Check the contactors		•		
24	Check the frame leakage (insulation test)		•		
25	Check function and wear of the accelerator		•		
26	Check the electrical system of the drive motor		•		
Braking system					
27	Check brake performance, if necessary replace the brake disc or adjust the air gap		•		
Battery					
28	Check the battery voltage		•		
29	Clean and grease the terminals and check for corrosion and damage		•		
30	Check the battery housing for damages		•		
Charger					
31	Check the main power cable for damages			•	
32	Check the start-up protection during charging			•	
Function					
33	Test the audio warning signal	•			
34	Check the air gap of the electromagnetic brake	•			
35	Test the emergency braking	•			
36	Test the reverse and regenerative braking	•			
37	Test the safety (belly) button function	•			
38	Check the steering function	•			
39	Check the lifting and lowering function	•			
40	Check the tiller arm switch function	•			
41	Test the key switch of damages and function	•			
42	Test the speed limitation switch (lifting height >~300mm)	•			
General					
43	Check if all decals are legible and complete	•			
44	Check if the protective screen and or guarding is not damaged	•			
45	Inspect the castor, adjust the height or replace it, if worn out		•		
46	Carry out a test run	•			

b. Lubricating points

Lubricate the marked points according to the maintenance checklist. The required grease specification is: DIN 51825, standard grease.

- 1 Bearings in wheels
- 2 Main frame post
- 3 Chain
- 4 Hydraulic system
- 5 Steering bearing
- 6 Gear box

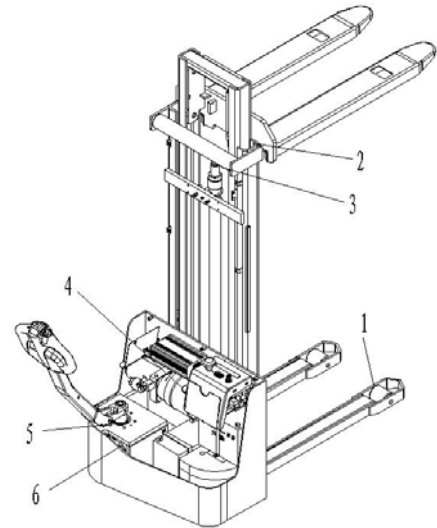

Fig. 16: Lubricating points

c. Check and refill hydraulic oil

The required hydraulic fluid- type is

- H-LP 46, DIN 51524
- Viscosity is 41.4 - 47
- Depending on the type the amount is ~ 2,5L to 3,0L

Waste material like oil, used batteries or other must be probably disposed and recycled according to the national regulations and if necessary brought to a recycling company.

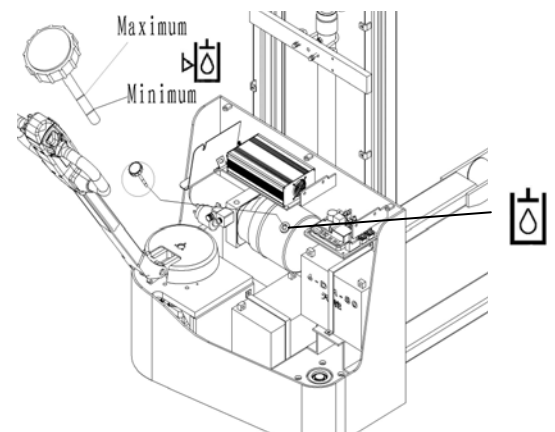

Fig. 17: Oil level

d. Checking electrical fuses

Remove the main cover. The fuses are located according to fig. 20; the size is according to table 5.

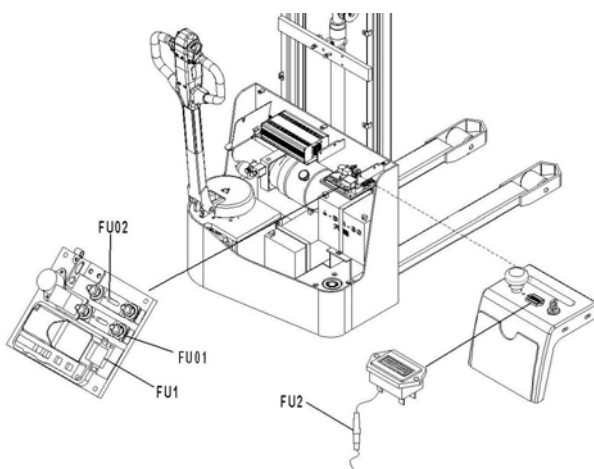

Fig. 18: Location fuses

Table 5: Size of the fuses

	Rate
FU1	10A
FU2	
FU 01	60A
FU 02	100A

e. Removing, reattaching guarding



DO NOT USE THUIS TRUCK, IF THE GUARDING IS DAMAGED OR NOT CORRECTLY ASSEMBLED!

If the guarding needs to be removed, unbolt the fixing screws and remove the screen carefully. The screws will remain with the screen. For reattaching place the screen to the right position and fix each screw correctly. If you need to replace parts, please call your next service partner.

7. TROUBLE SHOOTING



- If the truck has malfunctions follow the instructions, mentioned in chapter 6.

Table 6: Trouble shooting

TROUBLE	CAUSE	REPAIR
Load can't be lifted	Load weight too high	Lift only the max. capacity, mentioned on the ID-plate
	Battery discharged	Charge the battery
	Lifting fuse faulty	Check and eventually replace the lifting fuse
	Hydraulic oil level too low	Check and eventually refill hydraulic oil
	Oil leakage	Repair the hoses and/or the sealing of the cylinder
Oil leakage from air breathing	Excessive quantity of oil.	Reduce oil quantity.
Load can't be lowered	Dirty oil blocks control valve.	Check hydraulic oil and clean control valve. Replace the oil if necessary.
	The solenoid valve for lowering is not opened or is damaged.	Check or replace the valve for lowering.
Stacker not starts operating	Battery is charging	Charge the battery completely and then remove the main power plug form the electrical socket.
	Battery not connected	Connect the battery correctly
	The fuse is faulty	Check and eventually replace fuses
	Battery discharged	Charge the battery
	Combined emergency switch is activated	De-activate the combined emergency switch by insert and pull the knob.
	Tiller in the operating zone	Move the tiller firstly to the braking zone.

Only travelling in one direction	The accelerator and the connections are damaged.	Check the accelerator and the connections.
The stacker only travels very slowly	The battery is discharged.	Check the battery status at the discharge indicator
	The electromagnetic brake is engaged.	Check the electromagnetic brake
	The relating tiller cables are disconnected or damaged	Check the tiller cables and connections.
The stacker starts up suddenly	The controller is damaged.	Replace the controller.
	The accelerator not moves back to its neutral position.	Repair or replace the accelerator.

If the truck has malfunctions and can't be operated out of the working zone, jack the truck up and go with a load handler under the truck and safe the truck securely. Then move the truck out of the aisle.

8. WIRING/ CIRCUIT DIAGRAM

a. Electrical circuit diagram

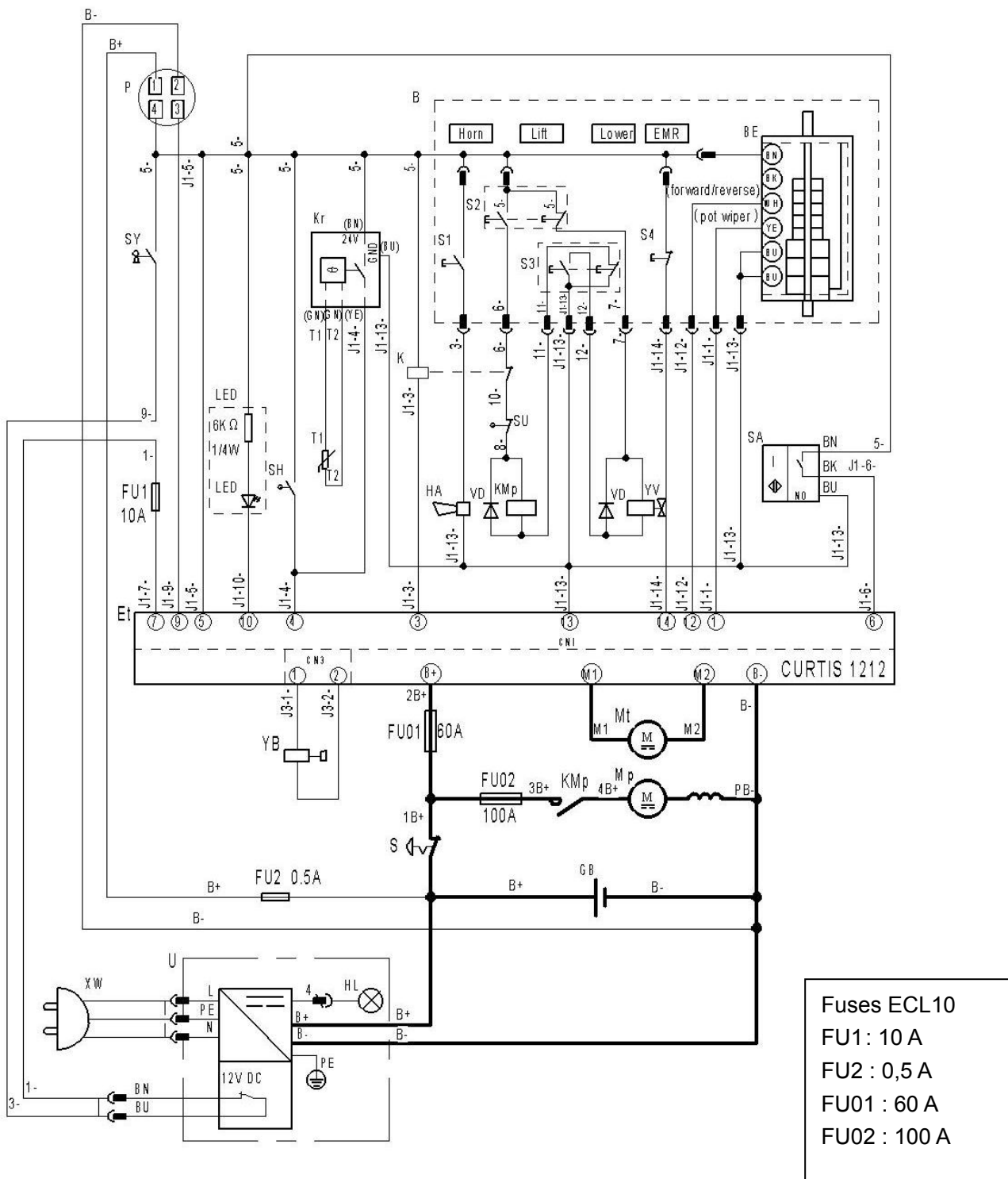

Fig. 19: Electric diagram ECL10

b. Hydraulic circuit

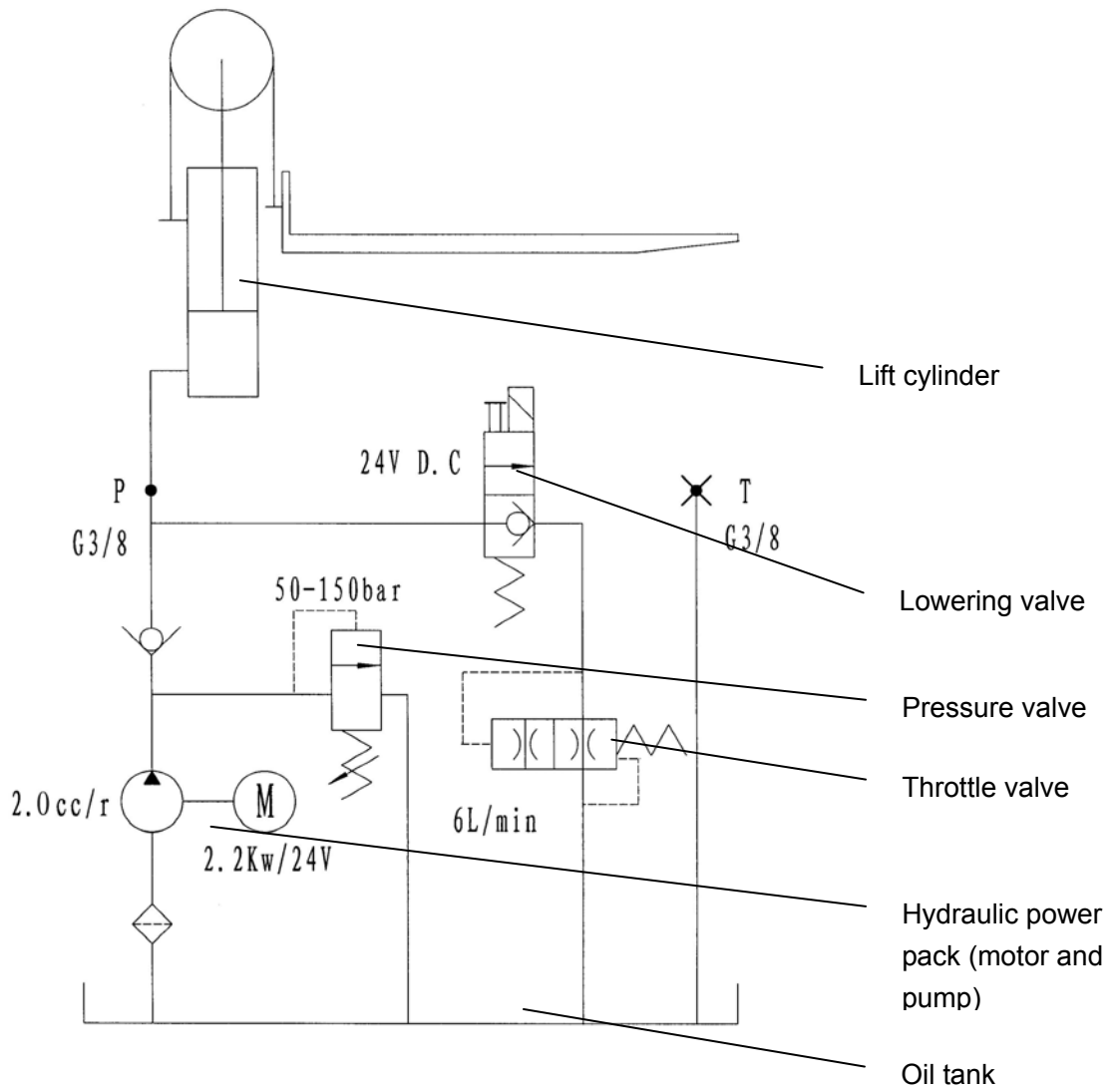

Fig. 20: Hydraulic circuit ECL10

9. SPECIALIZED STIPULATIONS FOR THE US- AMERICAN MARKET

The content in this chapter is specialized for the US-American market.

a. Foreword/ Compliance

Operating this truck requires knowledge which can be acquired from this instruction handbook. This handbook must be kept available throughout the entire period of use of the industrial truck.

IT IS LAW; YOU MUST BE TRAINED AND CERTIFIED TO OPERATE THIS TRUCK! READ AND OBEY ALL WARNINGS AND INSTRUCTIONS IN THIS MANUAL AND ON THE TRUCK!

Only properly trained operators are allowed to operate a powered industrial truck. Your employer must train you and certify, that you are qualified to operate this truck (required by OSHA § 1910.178). The training must satisfy OSHA requirements and as minimum the topics mentioned in this handbook. Depending on the context in this operating manual, the user can refer to several people, including the owner of the truck, anyone who leases or borrows this truck, and the operator as defined in ASME B56.1. Please pay attention to the section in ASME B56.1 concerning the operator. In this standard, it is defined that the safe operation is the responsibility of the operator (ASME B56.1-2003, Part II, section 5.1.1). You and others can be seriously injured or even killed if you don't use this truck correctly. Before operating your truck, inspect your truck and ensure that it is in correct working order. This truck was designed and built to current industry and government standards. For more information see following:

- ASME B56.1 (American Society of Mechanical Engineers)
- OSHA §1910.178 (Occupational Safety and Health Act)
- UL 583 (Underwriters Laboratory)
- ANSI Z535.4 (American National Standards Institute)

 **DANGER** This sign indicates hazard situations, if not avoided, will result in serious injury or death. The instructions or precautions to this message must be observed to avoid the potential risk of injury or death.

 **WARNING** If not followed, warning indicates hazard situations which may lead to moderate injury. The instructions or precautions to this message must be observed to avoid the potential risk of injury or death.

 **CAUTION** If not followed, caution indicated situations which may lead to minor injury. Instructions or precautions must be observed to avoid minor injury.

b. Description warning labels (only US- market)

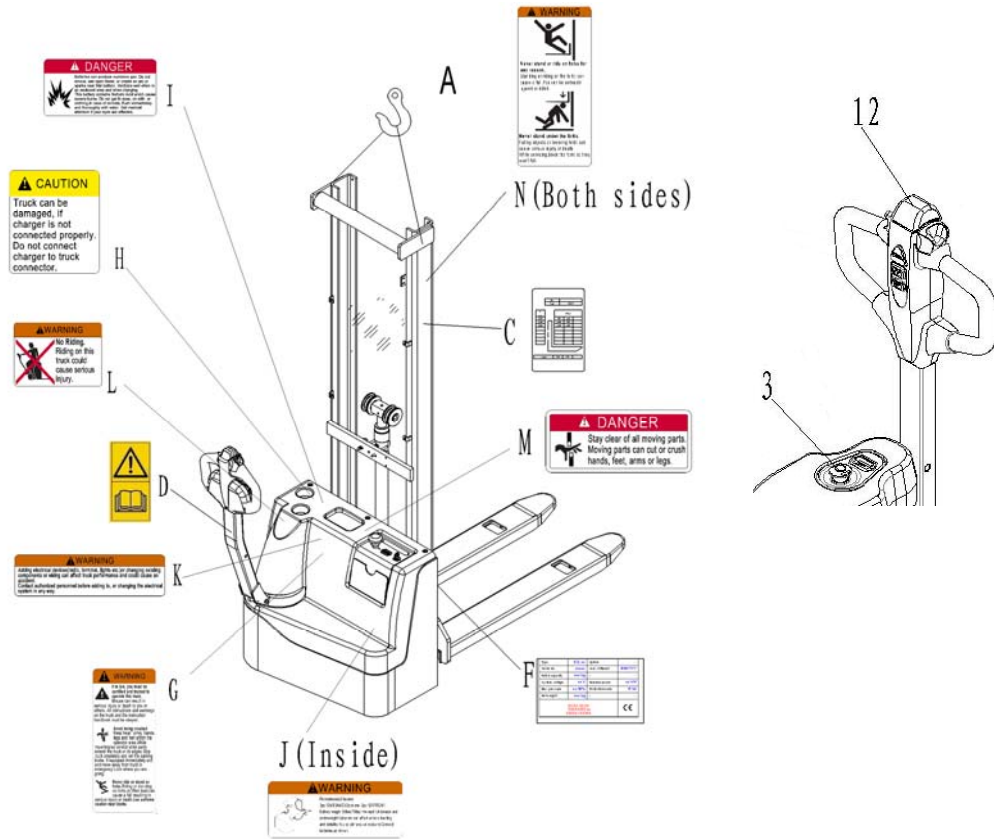

Fig. 30: Warning labels and safety devices (only USA)

- | | |
|---|-----------------------------------|
| A Crane hook label | H Sign Caution charger |
| B (used only outside US) | I Sign danger battery |
| C Residual lift capacity sticker | J Sign warning battery size |
| D Sticker to read and follow these instructions | K Sign warning electrical devices |
| E (used only outside US) | L Sign danger not riding |
| F Identification plate (ID-plate) | M Sign danger being crushed |
| G Sign warning stay clear stop truck | 3 Combined emergency switch |
| | 12 Safety (belly) button |

The truck is equipped with a combined emergency switch (3) which stops all lifting-, lowering-, driving- functions and engages the failsafe electromagnetic brake when it is pushed. The function is described in chapter 2c. Follow the instructions given on the decals. Replace the decals if they are damaged or missing.

Sign read and follow this instruction (B)



Sign warning stay clear stop truck (G)

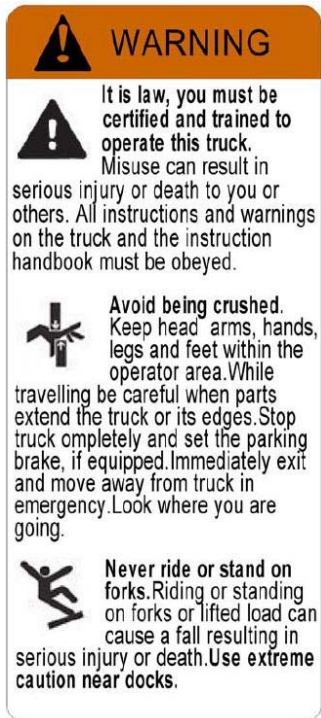

Sign Caution charger (H)



Sign danger battery (I)



Sign warning battery size (J)



Sign warning electrical devices (K)



Sign danger not riding (L)



Sign danger being crushed (M)



Sign not under, on forks



10. DECLARATION OF CONFORMITY (valid, if sold within the EU)

[GB] CE Declaration of Conformity

The signatory hereby declares that the specified machine conforms to the EU Directive 2006/42/EC (Machine Directive) and 2004/108/EEC (Electro-Magnetic Compatibility, EMC) including their amendments as translated into national legislation of the member countries. The signatory is individually authorized to compile the technical documents.

[D] EG-KONFORMITÄTSERKLÄRUNG

Der Unterzeichner bescheinigt hiermit, dass die im Einzelnen bezeichnete Maschine den Europäischen Richtlinien 2006/42/EG (Maschinenrichtlinie) und 2004/108/EG (Elektromagnetische Verträglichkeit - EMV) einschließlich deren Änderungen sowie dem entsprechenden Rechtsersatz zur Umsetzung der Richtlinien in nationales Recht entspricht. Der Unterzeichner ist bevollmächtigt, die technischen Unterlagen zusammenzustellen.

[E] DECLARACIÓN DE CONFORMIDAD CE

El signatario certifica por medio de la presente que la máquina especificada cumple con las Normas Europeas 2006/42/CE (Normativa para maquinarias) y 2004/108/CE (Compatibilidad electromagnética), incluyendo sus respectivas modificaciones, así como con el decreto-ley para la adaptación de las normas al derecho nacional. El signatario dispone de una autorización individual que le permite compilar la documentación técnica.

[F] DECLARATION DE CONFORMITE CE

Par la présente déclaration, les soussignés certifient que le machines spécifié ci-dessus est conforme à la loi et aux directives européennes 2006/42/CE (directive sur les machines) et 2004/108/CEE (compatibilité électromagnétique - CEM), y compris aux modifications qui y sont apportées et à l'arrêté autorisant sa transposition en droit national. Chaque signataire est habilité à établir individuellement la documentation technique.

[NL] EG-CONFORMITEITSVERKLARING

Ondergetekenden verklaren hierbij dat - volgens de nationale wetgeving van de Lidstaten - de hierboven vermelde opgegeven machina beantwoordt aan de bepalingen qua veiligheid bij machines (EG richtlijn 2006/42/EC) en electro-magnetische compatibiliteit (EG richtlijn 2004/108/EEC).

Ondergetekenden zijn ieder individueel gemachtigd het technisch dossier samen te stellen.

[P] DECLARAÇÃO DE CONFORMIDADE CE

Pela presente, os signatários certificam que o máquina especificada está conforme às Directivas Europeias 2006/42/CE („Máquinas“) e 2004/108/CEE („Inocuidade Electromagnética - IEM“), incluindo as alterações das mesmas e o respectivo decreto-lei para a transposição em lei nacional. Cada um dos signatários está autorizado a proceder à elaboração da documentação técnica.

[I] DICHIARAZIONE DI CONFORMITÀ CE

I sottoscritti dichiarano che il veicolo per trasporti interni a macchina specificato soddisfa le Direttive Europee 2006/42/EC (Direttiva Macchine) e 2004/108/EEC (Compatibilità elettromagnetica - EMV) comprese le relative modifiche, come pure il rispettivo decreto legislativo per la conversione delle direttive in diritto nazionale. I sottoscritti sono singolarmente autorizzati alla creazione della documentazione tecnica.

[BG] ЕВРОПЕЙСКА ОБЩНОСТ - ДЕКЛАРАЦИЯ ЗА СЪОТВЕТСТВИЕ

Подписаните удостоверяват с настоящето, че подробно описаното машина средство отговаря на европейския норматив 2006/42/EG (норматив за машини) и на 2004/108/EG (електро-магнетична съвместимост), включително с техните промени, както и на съответния указ за прилагане на нормативите в националното право. Подписаните при това са упълномощени поотделно да съставят техническата документация.

[CZ] EG - PROHLÁŠENÍ O SHODĚ

Níže podepsaný tímto potvrzuje, že podrobný popis uvedené stroje odpovídá Evropským směrnicím 2006/42/EC (směrnice pro stroje) a 2004/108/EEC (elektromagnetická interference - EMV) včetně jejich pozdějších úprav, jakož i příslušným právním výnosům pro uplatnění příslušné směrnice v rámci národního práva. Každý z podepsaných jsou jednotlivě způsobilí k vytvoření technických podkladů.

[DK] EF-OVERENSSTEMMELSEERKLÆRING

Undertegnede attesterer hermed, at det specificerede maskine stemmer overens med de Europæiske Direktiver 2006/42/EU (maskindirektiv) og 2004/108/EØF (elektromagnetisk kompatibilitet - EMC) samt med den modsvarende lovgivning til implementering af direktiver i den nationale lovgivning. De undertegnede er hver for sig beføjede til at sammenstille de tekniske dokumenter.

[EST] EL vastavusavaldus

Allakirjutatud tõendavad käesolevaga, et üksikasjaliselt kirjeldatud täpsustatud masin vastab Euroopa direktiividele 2006/42/EÜ (Direktiiv masinate kohta) ja 2004/108/EMÜ (Elektromagnetiline sobivus - EMS) kaasa arvatud nende muudatused ja nendele vastavatele õigusmäärustele direktiivide muutmiseks siseriiklikuks õiguseks. Iga allakirjutanu üksikult on volitatud koostama tehnilist dokumentatsiooni.

[FIN] EU-YHDENMUKAISUUSSELÖSTUS

Allekirjoittaneet todistavat täten, että kukin erikseen mainittu omalla voimanolähteellä varustettu tehdaskone vastaa EU-direktiivien 2006/42/EC (koneenrakennusdirektiivi) ja 2004/108/EEC (sähkömagneettinen yhteensopivuus – EMC) määräyksiä sekä niiden muutoksia ja niiden kansalliseen lainsäädäntöön soveltamista koskevaa oikeussäätöä. Jokaisella allekirjoittaneista on oikeus itsenäisesti laatia asiaankuuluvia teknisiä asiakirjoja.

[GR] ΔΗΛΩΣΗ ΣΥΜΜΟΡΦΩΣΗΣ ΕΟΚ

Οι υπογράφωντες βεβαιώνουν διά της παρούσης ότι το συγκεκριμένο μηχάνημα συμμορφώνεται προς την Κοινοτική Οδηγία 2006/42/ΕΚ («Μηχανήματα») και 2004/108/ΕΟΚ (Ηλεκτρομαγνητικής Συμβατότητας, ΗΜΣ), καθώς και οι τροποποιήσεις τους, όπως μεταφράστηκε στην εθνική νομοθεσία των χωρών μελών. Οι υπογράφωντες είναι σε κάθε περίπτωση εξουσιοδοτημένοι ατομικά να καταρτίσουν τα τεχνικά έγγραφα.

[H] EU KONFORMITÁSI NYILATKOZAT

Alulírottak ezennel igazolják, hogy a részletesen leírt a megadott gép megfelel a 2006/42/EC (Gép-Irányelv) és a 2004/108/EEC (Elektromágneses összeférhetőség - EMV) Európai Irányelveknek, beleértve azok módosításait, valamint az irányelvek nemzeti jogba történő átültetésére irányuló megfelelő jogi rendelkezést. Továbbá az alulírottak mindegyike rendelkezik meghatalmazással arra nézve, hogy összeállíthatja a műszaki dokumentációt.

[LT] ES atitikimø deklaracija

Žemiau pasirašę asmenys patvirtina, kad atskirai aprašytas nurodyta mašina atitinka Europos Sąjungos direktyvas 2006/42/EB (Mašinų direktyva) ir 2004/108/EEB (Elektromagnetinis suderinamumas – EMS) įskaitant jų pakeitimus, o taip pat ir atitinkamą teisės aktą dėl direktyvų įgyvendinimo nacionalinėje teisėje. Kiekvienas iš pasirašusių asmenų turi teisę ruošti techninę dokumentaciją.

[LV] ES atbilstības deklarācija

Ar zemāk redzamajiem parakstiem tiek apliecināts, ka norādīts mašina atbilst Eiropas Savienības normatīvam 2006/42/EG (Mašīnu normatīvas) un 2004/108/EWG (Elektromagnētiskā atbilstība – EMV), ieskaitot to izmaiņas, kā arī atbilstošos tiesiskos rīkojumus normatīvu pielāgošanai nacionālajai likumdošanai. Parakstu īpašnieki ir atsevišķi pilnvaroti sastādīt tehniskās dokumentācijas.

[N] EU-KONFORMITETSERKLÆRING

Undertegnede bekrefter hermed at de enkelte betegnede maskin med kraftdrift tilsvarer de europeiske retningslinjene 2006/42/EC (maskinretningslinje) og 2004/108/EEC (elektromagnetisk fordraglighet - EMV) inklusiv disses endringer og den tilsvarende rettsforordning til omsetning av nasjonal rett. Hver undertegnede er fullmektig til å sette sammen de tekniske dokumentene.

[PL] DEKLARACJA ZGODNOŚCI Z NORMAMI UE

Niżej podpisani potwierdzają niniejszym, że opisany tutaj, napędzany określona maszyna spełnia wymagania określone w dyrektywach Europejskich 2006/42/EC (Maszyny) i 2004/108/EEC (Nieszkodliwość elektromagnetyczna - EMC) wraz z ich późniejszymi zmianami oraz odpowiednimi rozporządzeniami mającymi na celu przekształcenie tych dyrektyw w prawo krajów członkowskich. Niżej podpisani są pojedynczo upoważnieni do zestawiania dokumentacji technicznej.

[RO] DECLARAȚIE DE CONFORMITATE CE

Subsemnatii adevăresc prin prezenta că vehiculul de specificat mașină descris individual corespunde directivelor europene 2006/42/CE (Directiva privind mașinile) și 2004/108/CEE (Compatibilitatea electromagnetică - CEM) inclusiv modificărilor lor precum și actului legislativ corespunzător prentru transpunerea directivelor în drept național. Subsemnatii sunt fiecare în parte împuterniciți să întocmească documentația tehnică.

[RUS] Декларация соответствия стандартам ЕС

Настоящим лица, подписавшие документ, удостоверяют, что машина с указанной спецификацией соответствует европейским стандартам 2006/42/EG (Транспортная директива) и 2004/108/EWG (Электромагнитная совместимость - EMC), включая изменения в них, а также соответствующим национальным стандартам и нормам. Каждое по отдельности лицо, подписавшее документ, имеет полномочия для составления технической документации.

[S] EG-KONFORMITETSFÖRKLARING

Undertecknarna intygar härmed att det i detalj betecknade maskin uppfyller de Europeiska direktiven 2006/42/EG (Maskindirektiv) och 2004/108/EEG (Elektromagnetisk tålighet - EMV), inklusive ändringarna i detta och den motsvarande rättsförordningen för att omsätta direktiven i nationell rätt. Undertecknarna har var för sig fullmakt att sammanställa den tekniska dokumentationen.

[SK] vyhlásenie o zhode

Dolu podpísaní týmto potvrdzujeme, že podrobný popis uvedené stroje zodpovedá Európskym smerniciam 2006/42/EC (ernica pre stroje) a 2004/108/EWG (elektromagnetická tolerancia – EMV) vrátane jeho neskorších úprav, rovnako zodpovedá aj príslušným právnym nariadeniam na uplatnenie smerníc v rámci národného práva. Každý z podpísaných je jednotlivo splnomocnený na vytvorenie technických podkladov.

[SLO] EU IZJAVA O SKLADNOSTI

Podpisani s tem potrjujemo, da posamično označeno določeno stroj vozilo odgovarja Evropski direktivi 2006/42/EC (Direktiva o strojih) in 2004/108/EEC (Elektromagnetna skladnost - EMV) vključno z njihovimi spremembami ter ustrezno pravno uredbo o prevzemu smernic v nacionalno pravo. Podpisniki so vsakokrat posamezno pooblašteni za izdajanje tehnične dokumentacije.

[TR] AB Uygunluk Açıklaması

İmza sahibi şahıslar, ayrıntıları belirtilen makine aracının, 2006/42/EC (Makine Yönergesi) ve 2004/108/EEC (Elektromanyetik Uyumluluk – EMC) no'lu Avrupa Yönergelerine ve bunların değişiklik sonucu oluşan metinlerine ve yönergelerin milli hukuk hükümlerine dönüştürülmesine dair ilgili hukuk karamamesine uygun olduğunu tasdik ederler. İmza sahibi şahıslar teknik dosyaları bir araya getirmek için münferiden vekil tayin edildi.

- (1) Type/ Typ/ Tipo/ Modello/ Тууыпи/ Tipo / ΤΥΠΟΣ/ Τίπος/ Τίρ/ Тип/ Tips/ Tipas/ Tüüp:
- (2) Serial No./ Serien-Nr./ N°. de série/ Seriennummer/ N° de serie/ Numero di serie/ Serienr./ Sarjanro/ αυξάνων αριθμός/ Seriové číslo/ Szériaszám/ Nr.Seryjny/ Serijska številka/ Výrobné číslo/ Серийный номер/ Seri No./ Seerianr./ Sērijas Nr./ Serijos numeris:
- (3) Year of constr./ Baujahr/ Année de constr./ Bouwjaar/ Año de constr./ Anno di costruzione/ Produktionsår/ Byggeår/ Tillverkningsår/ Valmistusvuosi / Ano de fabrico / έτος κατασκευής/ Rok výroby/ Gyártási év/ Rokprodukcji / Letnik / Год изготовления / Üretim yılı / Väljallaskeasta / Izgatavošanas gads / Gamybosmetai
- (4) Manufacturer or his authorized representative in Community/ Hersteller oder in der Gemeinschaft ansässiger Vertreter/ Fabricant ou son mandataire établi dans la Communauté/ Fabrikant of zijn in de Gemeenschap gevestigde gemachtigde/ Fabricante o representante establecido en la Comunidad/ Construtor ou Representante estabelecido na Comunidade/ Costruttore oppure il suo rappresentante nella Comunità/ Fabrikant eller dennesi Fællesskabet etablerede befuldmægtigede/ Produsent eller agent innen felleskapet/ Tillverkare eller representant inom EU/ Valmistaja tai yhteisömaassa oleva edustaja / V'robce nebo jeho zastoupení/ Gyártó / producent albo jego przedstawiciel w EG (Wspólnota Europejska)/ Κατασκευαστής ή όκνηνο ηνπηθώλ αληηπεινζώπσωλ/ Üretici ya da Bölgedeki Yetkili Temsilci/ Proizvajalec ali pooblašteni zastopnik s sedežem v EU/ V'robca alebo zástupca so stálym bydliskom v EÚ / Изготовитель или его представитель, зарегистрированный в стране Содружества/ Tootja või organisatsioonis paiknev esindaja/ Ražotājs vai vietējais uzņēmuma pārstāvis / Gamintojas arba šalyje reziduojantis atstovas:
- (5) Date/ Datum/ Data/ Fecha/ datum/ Dato/ päiväys/ Kuupäev/ Datums/дата / Datum/ dátum/ tarih/ ημερομηνία
- (6) Authorised signatory/ Im Auftrag/ pour ordre/ Incaricato/ Por orden de/ por procuração/ op last van/ på vegne af/ på uppdrag/ Etter oppdrag/ psta./ Ülesandel / pavedus / v.i. / По поручению / megbizásából / длъжностно лице / z pověření / z poverenia / po nalogu / na polecenie / din sarcina / adına / θαη' εληνηή

If you can read this text:

- Your truck might be sold outside the EU; this declaration is then not valid.
- Your present version is a (printed) e-document
- The declaration is not complete.
In this case please ask for a copy