



OPERATION MANUAL

ELECTRIC MINI CHAIN HOIST



DUKE Electric Mini Chain Hoist Introduction

The DUKE Electric Mini Chain Hoist is designed for various workplace applications, such as general factories, warehouse, construction, plumbing, agriculture industries, unique rigging applications encountered at small venues, lightweight, quiet, and portable.

CONTENTS

1. Preface	3
2. Safety Instruction	4
2-1 Safety regulations	4
2-1-1 General safety rules	4
2-1-2 Electrical safety rules	5
2-1-3 Safety rules of hoist	6
2-2. All safety related elements	7
2-3. Checklist of electrical and safety function	8
3. Mini Chain Hoist Description	9
3-1 General characteristics	9
3-1-1 Usages	9
3-1-2 Features	9
3-2 Specifications	10
3-3 Overall dimensions	11
3-4 Working space required and operating position	12
3-5 Main units and name	13
4. Pre-use Preparation	14
4-1 Notice and inspection before operating	14
4-1-1 Mechanical Check	14
4-1-2 Electrical Check	14
4-2 Expected use and limits of use	15
5. Transport, Install and Dismantle	16
5-1 Transport	16
5-2 Install	17
5-2-1 Power & Control System	17
5-2-2 Preliminary Checks	17
5-2-3 Continuous rating	21
6. Operation	22
6-1 Control device: Control panel	22
6-2 Operating procedure	22
6-3 Handling precautions	23
7. Maintenance and Adjustment	24
7-1 Inspections & Maintenance	24
7-2 Troubleshooting	31
8. Drawings and Part list	34
8-1 Assembly drawings and part list	34
8-2 Electrical system drawings and part list	38

1. Preface

- Please read this Instruction Manual carefully before you start using the electric winch. You will find many useful hints which will help you to keep the winch always in its first-class condition.
- You are kindly requested to read this manual thoroughly, to follow scrupulously the instructions given and for safety reasons, avoid controlling, adjusting or performing procedures other than those specified.
- This winch has been designed and built in full compliance with EN ISO 12100, ISO 14121 and EN 60204 standards on machine and further modification, with high-quality materials and particularly studying the possibilities to reduce as much as possible the risks of accident.
- Foreword to the operating instructions
The operating instructions are designed to familiarize the user with the winch and its designated use.
- The instruction manual contains important information on how to operate the winch safely, properly and most efficiently. Observing these instructions helps to avoid danger, to reduce repair costs and downtimes and to increase the reliability and life of the winch.
- The instruction manual is to be supplemented by the respective national rules and regulations for accident prevention and environmental protection.
The operating instructions must always be available wherever the winch is in use. These operating instructions must be applied by any person in charge of carrying out work with and on the winch, such as
 - operation including setting up, troubleshooting in the course of work, care of consumables
 - maintenance (servicing, inspection, repair) and/or
 - transport

This electric winch is designed and built in full compliance with the safety standard, please read carefully before installing the machine. You will find many hints to keep the machine in its best condition, also to avoid the risk of accident.
- In addition to the operating instructions and to the mandatory rules and regulations for accident
- Prevention and environment protection in the country and place of use of the winch, the generally recognized technical rules for safe and proper working must also be observed.

2. Safety Instruction

2-1 Safety regulations

2-1-1 General safety rules

1. This electric hoist is designed for lifting products only. Do not apply the electric hoist for lifting person.
2. The electric hoist should be mounted on a flat solid place.
3. Installing the electric hoist at a proper levelling condition to ensure the chain arranged neatly. This may avoid chain friction against the hoist body.
4. Make sure your power source comply with the voltage indicated on the electric hoist before connecting the power wires to the power source.
5. Connect the power wires. Tighten the terminals securely.
6. Make sure the electric hoist has been properly grounded. The power circuit should be equipped with an electric shock breaker.
7. Before operating the electric hoist, read and follow the instructions for allowable lifting weight, speed and voltage etc. Indicated on the attached plate.
8. Do not exceed the rated lifting capacity of the electric hoist. Allowable lifting weight is indicated on the attached plate.
9. The electric hoist should be operated by a skilled operator. Before operating the electric hoist check again if all lock screws are tightened securely without loosening.
10. Before operating the electric hoist check to see if the chain runs to the correct direction and the brake works normally.
11. Do not allow any person approaches under the electric hoist, bracket or weight.
12. Select a proper location for mounting the electric hoist, to prevent the lifting weight bumping against any construction, steel frame or construction beam etc while lifting.
13. Always keep the chain in a good condition.
14. Lift weight vertically. Do not lift weight in a slant or horizontal direction. Do not have weight hooked on the chain for a long time.
15. Do not use the electric hoist to pull out any object fixed in the floor or any construction.
16. When the electric hoist is running, keep your hands or any object away from it to avoid danger.
17. Prevent control wire or power wire from hooking or contacting by the chain. This may avoid electric shock or any danger.
18. In case any malfunction or abnormal noise occurs during operation, stop the electric hoist immediately. Check and repair it immediately for safety.
19. Do not alter the electric circuit or use any other replacement parts not supplied from the original manufacturer.. This avoids affection on the hoist performance or any accident.
20. The operator is requested to fully obey the safety rules listed for safety protection.

2-1-2 Electrical safety rules

1. Before installing, please pay attention to the input rated voltage and current and make sure the hoist is grounded, in order to prevent accident.
2. There must be a main power switch at main input side of electric control system.
3. Remember to disconnect the main power before repair, maintenance and clean.
4. Unauthorized or untrained personnel cannot repair or maintain any electric equipment.
5. Comply with the maintenance instruction to repair and maintain the electric equipment.
6. Before operating the hoist, check all of the electric equipments and parts are broken or damaged or not. If there is something broken or damaged, replace a new one immediately and please note its original rated specification.
7. After connecting power, check the direction of motor rotation and the direction of hoist is correct or not.
8. Please check whether the function of emergency stop button is normal or not. The emergency stop button is used under emergency situation to cut off power of hoist. (Operator usually misunderstand that the hoist is broken down when they forgot to release the emergency stop button.)
9. Please check whether the function of each safety parts is normal or not, such as emergency stop button, emergency stop wire, interlocking switch, main power switch, safety valve, limit switch, and etc.
10. Please check whether the screws of each terminal base are tightened or not. If the screws loose, screw them tightly.
11. The wiring practices of electric control system must be complied with circuit diagram.

2-1-3 Safety rules of hoist

1. Don't misuse the hoist, to avoid danger.
2. Before start the hoist, make sure all the protecting covers are not breakdown and damage.
3. If the mechanism or any part breakdown, operator should stop the hoist immediately and then examine and repair it.
4. If it results abnormal sound during operation, operator should stop the hoist immediately and then examine and repair it.
5. If abnormal temperature phenomenon happens during operation, operator should stop the hoist immediately and then examine and repair it.
6. Don't modify the original design of mechanical structure, in order to keep the best efficiency and security.
7. Please store the spare parts and tools well, and avoid moist and damage.
8. Untrained or unauthorized operator is prohibited operating, installing or maintaining hoist.
9. Please maintain and repair the hoist according to service instruction.
10. Please replace broken part according to the specification in part list.

2-2. All safety related elements

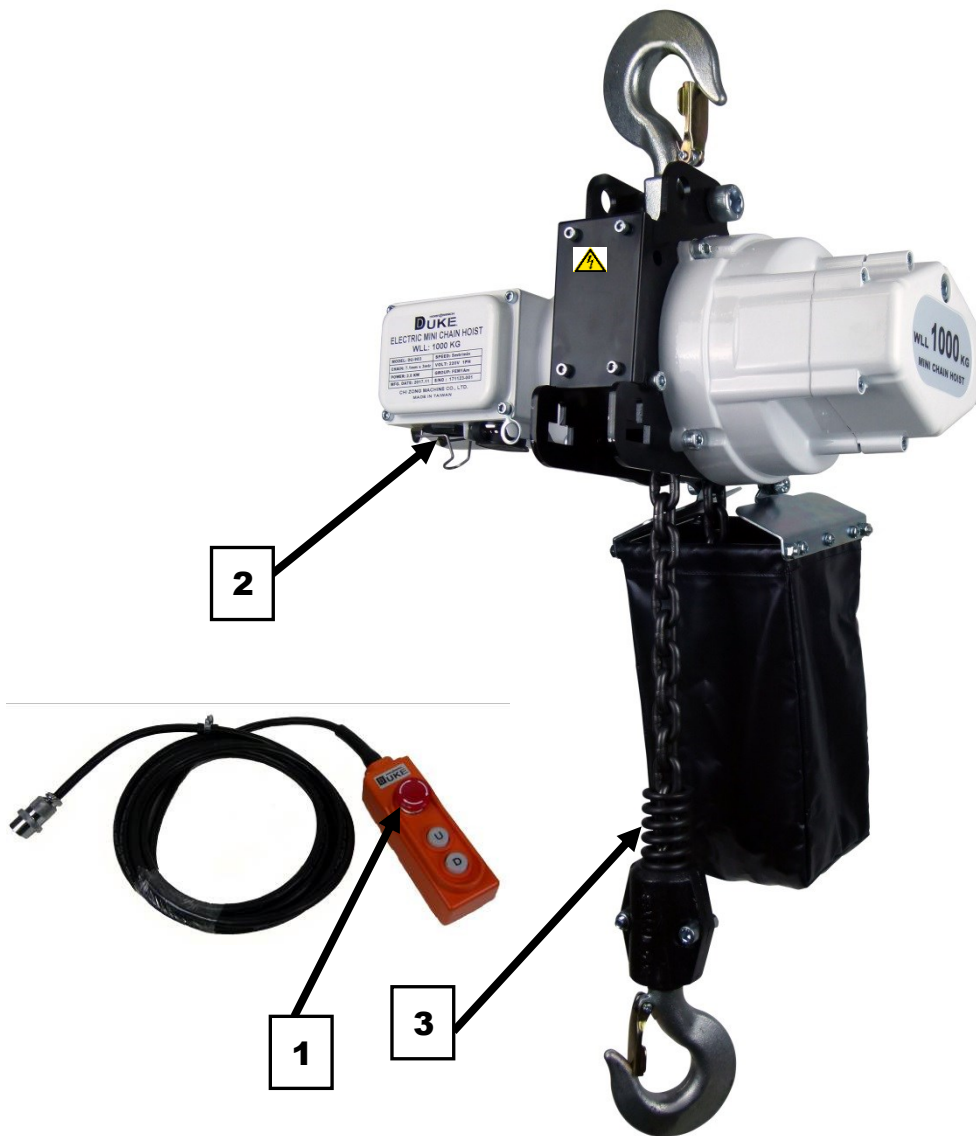

ITEM	DESCRIPTION
1	EMERGENCY STOP
2	FUSE
3	Chain Guide Spring

2-3. Checklist of electrical and safety function

Item	Content inspection and safety requirement	Result	Comment
1	Is every terminal protected by isolation plate (IP2X)?	YES	
2	Does technician follow the procedure number to wire?	YES	
3	Are the diameter of grounding wire and each circuit accord with safety requirement of designed electrical circuit?	YES	
4	Is fuse accord with safety requirement of designed electrical circuit?	YES	
5	Are these screws on electric box fixed tightly?	YES	
6	Is the electric box equipped with a ventilator (e.g. fan)?	YES	
7	Does the design of electric box conform to IP requirement?	YES	
8	Is all the function of every control switch and component described specifically on this operation manual?	YES	
9	Are input voltage, frequency, and phase marked correctly?	YES	
10	Is the machine earthed?	YES	
11	Is there an independent earth copper plate equipped inside electric box?	YES	
12	Is every function of control device regular?	YES	
13	Is the emergency stop device functional?	YES	
14	Is the rotary direction of motor or transmission correct?	YES	
15	Is the cover functional (fixed or movable)?	YES	
16	Is the machine set stable?	YES	
17	Have all the acute angle and fur been ground?	YES	
18	Has the machine been pasted a CE mark?	YES	
19	Has the machine been pasted a nameplate?	YES	
20	Has the machine been pasted related warning marks?	YES	
21	Have the listed related safety parts in TCF 1.6 been installed indeed?	YES	
22	Have all the safety information and attentions been provided completely for user?	YES	
23	Does the written language of manual and machine conform to local country?	YES	
24	Has the operation manual been provided?	YES	
25	Has the EC Declaration of Conformity been signed?	YES	

3. Mini Chain Hoist Description

3-1 General characteristics

3-1-1 Usages

Fit for various workplace applications, such as general factories, warehouse, construction, plumbing, and agriculture industries. Designed for unique rigging applications encountered at small venues, lightweight, quiet, and portable. Operates on 220V-240V, which means you can plug it in just about anywhere.

3-1-2 Features

Braking: Dual braking system combines mechanical plus regenerative braking, provides instant and safe braking.

Gearing: Precision machined gears heat treated for strength and durability, the ball or needle bearings at all rotating points run in oil bath lubrication for a quieter, smoother and cooler operation.

Loading sheave: Provide smooth lifting, reduce vibration and wear.

Housing: Lightweight, cast aluminum alloy

Friction clutch: A high performance and durability friction clutch that is integrated with the load brake. This design is to slip in order to prevent overloading and over travel that could damage the hoist.

Chain: Designed and manufactured by FEC, Japan, grade 80 alloy steel with resistance and long life service.

Chain bag: The vinyl chain bag container is provided standard with hoist.

Switch: Simply layout of the control with 3M power cable as standard and emergency stop as option.

3-2 Specifications

Model	DU-903	DU-904
Dimensions		
Length (mm)	456	456
Width (mm)	212	214
Height (mm)	535	675
Capacity (kg)	1000	2000
Standard Lift(m)		
Control Cable(m)	3	3
Lifting Speed(m/min)	50HZ-4 60HZ-5	50HZ-2 60HZ-2.5
Chain(mm)	7.1x20	7.1x20
Safety Factor	WLL x 1.25	
Insulation Class	F	
ED%	30%	
No. Of Starts per hr	180	
Power Cable (m)	5	5
Net Weight (kg)	23	28

3-3 Overall dimensions

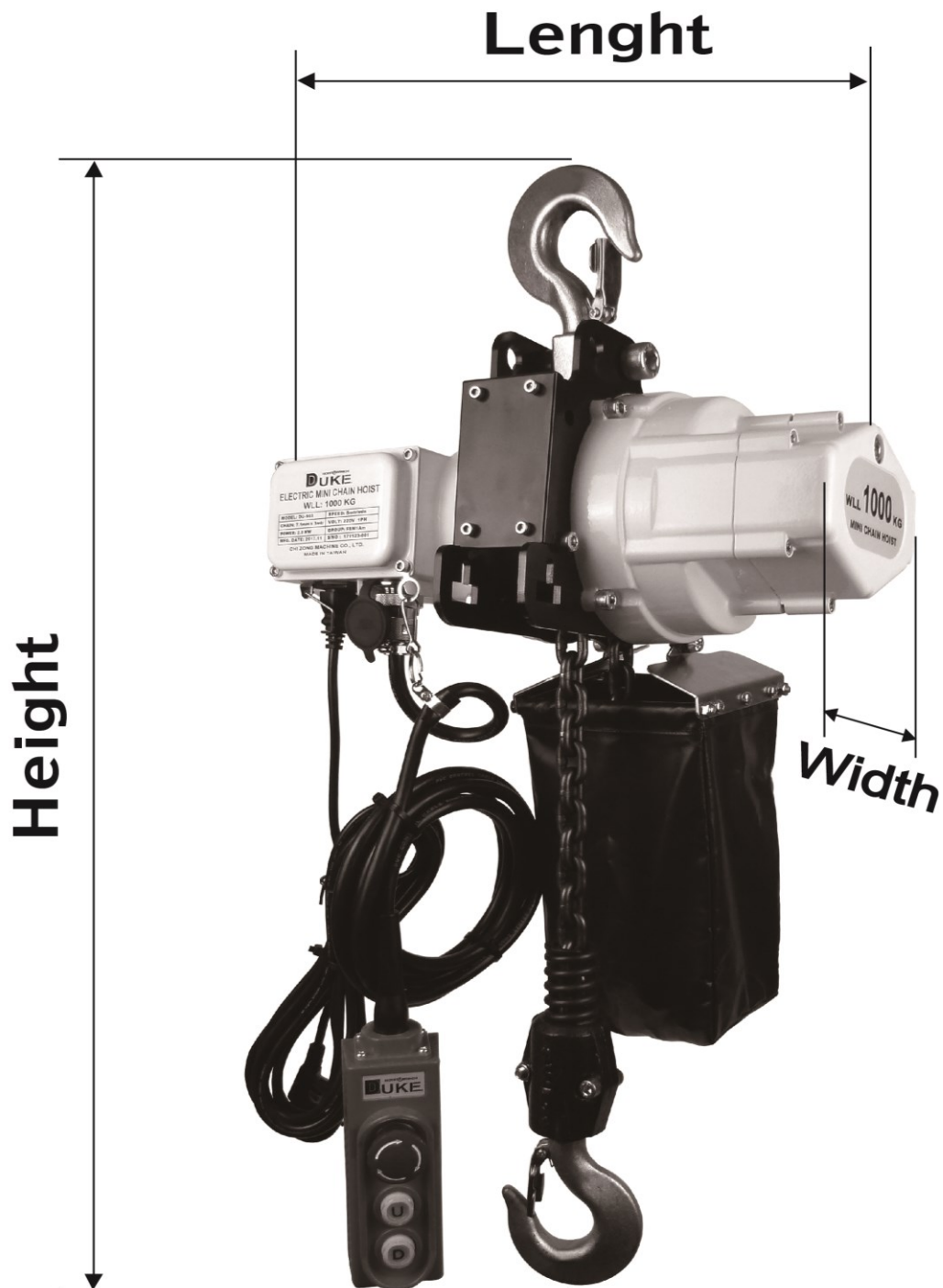

MODEL	Length	Width	Height
DU-903	456mm	212mm	535mm
DU-904	456mm	214mm	675mm

3-4 Working space required and operating position



FRONT OPERATOR

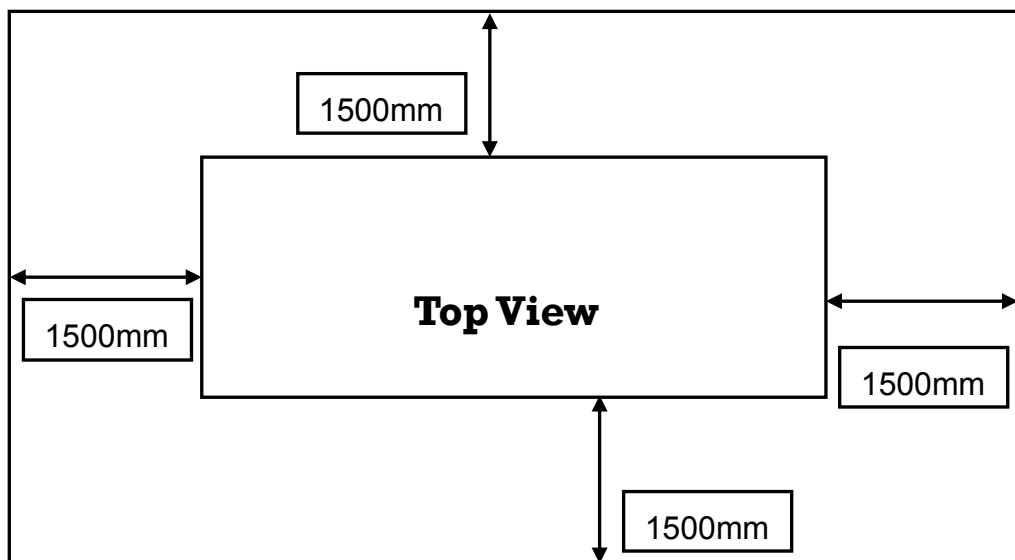

FRONT OPERATOR



3-5 Main units and name

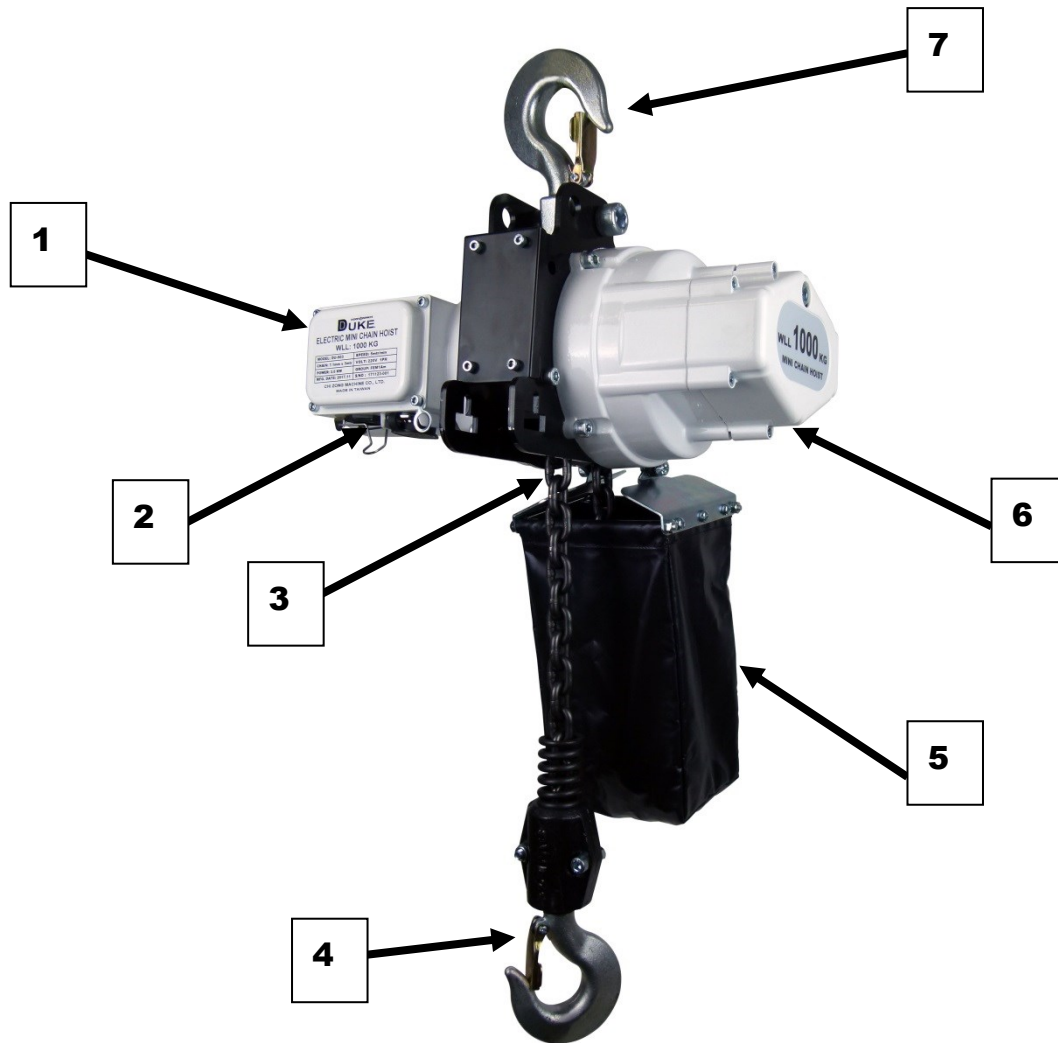

Item	Part's name
1	Electric Department
2	Motor
3	Chain - 7.1mm x 20mm
4	Lower Hook
5	Chain bag
6	Gear Box
7	Upper Hook

4. Pre-use Preparation

4-1 Notice and inspection before operation

4-1-1 Mechanical Check

1. Are all transport protection facilities removed?
2. Is there any mechanical damage?
3. Are all the safety device, safety covers refitted from the set-up installation?
4. Are all winch unit correctly aligned and locked in position?
5. Are all mobile and rotating parts exempt of foreign bodies? Is there mobility unimpaired (tools wire, yarns, waste, etc.)

4-1-2 Electrical Check

1. Are all ground conductors connected?
2. Are all cables connected?
3. Is there any mechanical damage of electrical control operating and indicator units
4. Are all plug-in connection to the hoist fitted correctly?
5. Are all the cable near mobile parts fixed correctly?
6. Are the cable fitting tightened?
7. Were chain rests and metal objects removed and cleaned away from switch box, junction box, control cabinets, and operating panel?
8. Are frequency inverters motor set for the correct V/Hz ratio if applied?
9. Are the drive rotating direction correct?

4-2 Expected use and limits of use

Specification of essential parts:

Please refer to the list of specification in operation manual.

This winch is expected to be used under industrial environment:

The well lighting, well ventilation, clean environment, dry, and maintains a normal temperature.

The winch needs the following supplies:

Electric power: single phase / 220-240V / 50Hz and 60Hz (or base on previous designation).

Working Duty (ED%):

30%.

No more than 20 minutes use within 60 minutes frame.

The required technique and experience during safety operation and use.

They should be a proficient operator or trained staff.

5. Transport, Install and Dismantle

5-1 Transport

Always carry the winch with two hands to prevent a strike.

Below table shows net weight and gross weight for each model of winch.



MODEL	NET WEIGHT	GROSS WEIGHT
DU-903	23 KGS	26 KGS
DU-904	28 KGS	31 KGS

5-2 Install

5-2-1 POWER & CONTROL SYSTEM

REQUIREMENTS

The DUKE hoist comes in a direct control. They must be connected to a power and control system that is properly designed to operate the chain hoist and to handle the power consumption of the motor. DUKE hoists are standard wired for 220V-240V-1ph-50/60Hz.



5-2-2 PRELIMINARY CHECKS

Before installing / starting to use the chain hoist, check the following:

General:

1. After unpacking the unit, carefully inspect for any damage that may have occurred during transit. Check for loose, missing or damaged parts. Shipping damage claims must be filed with the carrier. Be sure that the voltage labeled on the unit matches your power supply.
2. Make sure all supporting structures and attaching devices have the strength to safely absorb the weight of the intended loads. If in doubt, consult a qualified structural engineer. Power cables to chain hoists must include a ground conductor. If in doubt, consult a qualified structural engineer.
3. Chain hoists should not experience voltage drops of more than 10% of the supply voltage. It is critical to use adequate sized power cable.
4. The user's control board must be grounded in accordance with the electrical codes that are applicable in the local area. Power cable to chain hoists must include a ground conductor. The power cable includes a yellow/green ground conductor.
5. The installation area must provide safe operating conditions for the operator, including sufficient room for the operator and other personnel to stand clear of the load at all times.

RIGGING THE HOIST:



CAUTION

Part of this procedure can involve working from an elevated platform, scissors lift or cherry picker. Before doing so make sure you are competent to work with those and take all safety precautions needed.

1. Before each use, visually inspect the hoist and all load bearing parts of the hoist, like hook and chain.
2. Make sure the intended structural support component is able to safely absorb the chain hoist lifting capacity.
3. Attach the chain bag to the chain bag ring.
4. Put the chain into the chain bag and make sure there are no twists or knots in the chain in the chain bag.
5. Attach the chain hook to the main structural support member, either direct to an existing eyebolt or lug-plate, or using a bracket or beam clamp. It is also possible to use a sling or bridle. Avoid slinging on sharp edges.



WARNING

A fully loaded motor can put considerably higher forces to the support structure when dynamic forces are induced. A similar thing happens when a lowering movement of other hoists on the same load (e.g. truss-structure) causes the centre of gravity to slide towards the resting hoist, which will get overloaded. Overload protection in the chain hoist causes the structure to be overloaded as well.

6. Connect the power (and control) cable and make sure these will have proper stress relieves and sufficient slack in every direction of planned tilting of the load. Use Velcro or cable-strings to tie the cable to the hoist body or lifting hook.
7. Lower the chain hook by letting the chain run out to the required height.
8. Put the load under the chain hook.
9. Attach the load to the chain hook, either to a lug plate, eyebolt or using one or more slings.



10. Run the chain up until the load chain just taut.
11. Check all lifting and slinging connections, and lift the load until it is freely floating of the ground.
12. Visually check the whole lifting structure from chain hoist and cable through the load chain down to the load.



13. Remove all people from the area before you start lifting the load. Do not allow any people to stand under the moving load.
14. Make sure you have a full visual view on the complete travel path of the load.
15. Lift the load to the required height.



16. Add a secondary in between support structure and the load when persons have to

get under the load.

17. Make sure this secondary is as tight as possible, preferably using clutch-chains.



DE-RIGGING THE HOIST:

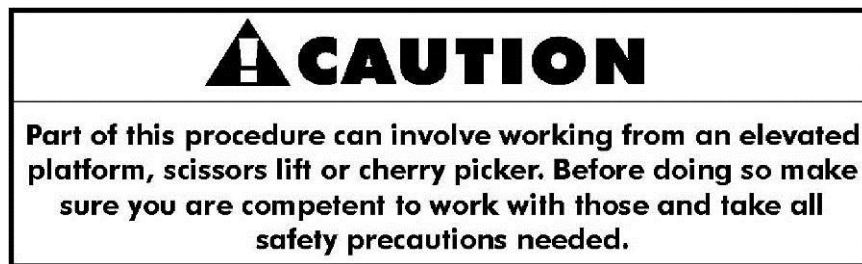

1. Remove the secondary (when present).
2. Check the direction of travel. If the pre-selection switch on the controller is in the down-direction the chain hoist should run in down-direction.
3. Check if both the lifting directions work properly (lifting and lowering).
Remove all people from the area before you start lowering the load. Do not allow any people to stand under the moving load.



5. Make sure you have a full visual view on the complete travel path of the load.
6. Bring the load down until within reach for further dismantling.
7. Remove all parts of the load and slings attached the chain hook.
8. Disconnect the power and control cables.
9. Remove the chain hoist from the suspension structure and bring it down.
10. Put the chain hoist and the chain bag in their compartments of the flight case (when applicable).
11. Remove any bracket, beam clamp or sling from the main structure elements.

5-2-3 Continuous rating

Never use the hoist beyond the 20 minutes permitted per hour.

The life of the hoist depends on the conditions of the load and working frequency. During long operating periods make sure to use the hoist within its continuous rating.

Continuous Rating means the amount of allowable usage within one hour which is 25% or 20 minutes per hour or 300 starts per hour.

The maximum number of starts means the number of times the motor starts within the hour.

6. Operation

6-1 Control device: Control panel

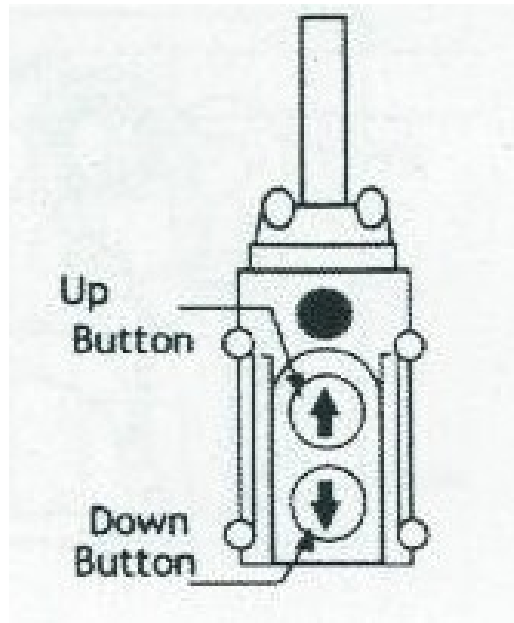

6-2 Operating procedure

The person who is untrained or unfamiliar with the operation procedure is prohibited from operating machine.

Preparation before Working

- Check all safety and environmental conditions
- Connect the main power source and ensure grounding.
- Do not lift loads exceeding the rated load.
- Always use power source at the rated voltage.

Up and Down Control Switch

- **To Lift a Load.** Press ▲ Button
- **To Lower a Load.** Press ▼ Button

6-3 Handling Precautions

1. Check to ensure that the load point is in the line with the hoist head.
2. When applying a load, it must be directly in line with hoist. Avoid off-center loading of any kind.
3. Take up a slack load chain carefully and start load easily to avoid shock and jerking of hoist load chain. if there is any evidence of overloading, immediately lower the load and remove the excess load.
4. Do not allow the load to swing or twist while lifting.
5. Do not allow the load and/or attachments to bear against the hook latch and/or hook tip. Apply load to hook bowl or saddle only.
6. The DUKE can be mounted upright as “motor up” in the traditional industry situation or “motor down”, which has become standard in the entertainment touring industry. Always ensure that it is clear whether the load chain shall move or whether the hoist housing shall move. This does have effect on the way power and control cables should be run.

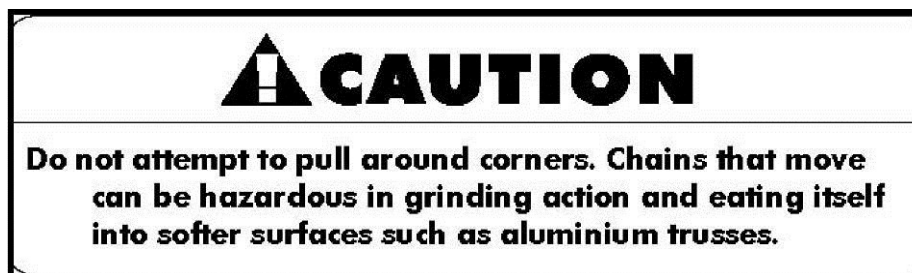

7. Maintenance and Adjustment

7-1 Inspections & Maintenance

To maintain continuous and satisfactory operation, a regular inspection procedure must be initiated to replace worn or damaged parts before they become unsafe. Inspection intervals must be determined by the individual application and are based on the type of service to which the hoist will be subjected to the degree of exposure to wear, deterioration or malfunction of the critical components.

The type of service to which the hoist is subjected can be classified as Normal, Heavy, or Severe.

Normal Service: Involves operation with randomly distributed loads within the rated load limit, or uniform loads less than 65% of rated load for not more than 25% of the time.

Heavy Service: Involves operating the hoist within the rated load limit which exceeds normal service.

Severe Service: Normal or heavy service with abnormal operating conditions.

Two classes of inspection- frequent and periodic – must be performed.

Frequent Inspections: These inspections are visual examinations by the operator or other designated personnel. Records of such inspections are not required. The frequent inspections are to be performed monthly for normal service, weekly to monthly for heavy service, and daily to weekly for severe service, and they should include those items listed in below.

Periodic Inspections: These inspections are visual inspections of external conditions by an appointed person. Records of periodic inspections are to be kept for continuing evaluation of the condition of the hoist.

Periodic inspections are to be performed yearly for normal service, semi-annually for heavy service and quarterly for severe service, and they are to include those items listed in below.

CAUTIONS: Any deficiencies are to be corrected before the hoist is returned to service. Also, the external conditions may show the need of disassembly to permit a more detailed inspection, which, in turn, may require use of nondestructive type testing.

PREVENTIVE MAINTENANCE

In addition to the above inspection procedure, a preventive maintenance program should be established to prolong the useful life of the hoist and maintain its reliability and continued safe use. The program should include the periodic and frequent inspections with particular attention being paid to the lubrication of the various components using the recommended lubricants.

Minimum Frequent Inspections

TYPE OF SERVICE			ITEM	
Normal	Heavy	Severe		
Monthly	Weekly to Monthly	Daily to Weekly	a)	Brake for evidence of slippage.
			b)	Control functions for proper operation.
			c)	Hooks for damage, cracks, twists, excessive throat opening, latch engagement and latch operation.
			d)	Load chain for adequate lubrication, as well as signs of wear or damaged links.
			e)	Load chain for proper reeving and twists.

Minimum Periodic Inspections

TYPE OF SERVICE			ITEM	
Normal	Heavy	Severe		
			a)	All items in minimum frequent inspections
			b)	External evidence of loose screws, bolts or nuts.
			c)	External evidence of worn, corroded, cracked or distorted hook block, suspension screws, gears, bearings, chain stop and chain guide.
			d)	External evidence of damage to hook retaining nut and pin. Also check the upper suspension adapter making sure it is fully seated in the hoist frame and that both screws are tight.
			e)	External evidence of excessive wear of brake parts.
			f)	Checking the operation of the control station making sure the buttons operate freely and do not stick in either position.
			g)	Inspect the electrical cords and cables and control station enclosure for damaged insulation.
			h)	Inspect the suspension hook for excess free play or rotation. Replace worn parts as evidence by excess free play or rotation.

HOOK INSPECTION

Hooks damaged from chemicals, deformations or cracks, or that have more than a 10 degree twist from the hook's unbent plane, excessive opening or seat wear must be replaced. Also, hooks that are opened and allow the latch to not engage the tip must be replaced. Any hook that is twisted or has excessive throat opening indicates abuse or overloading of the unit. Inspect other load sustaining parts, hook block screws, load pins and hook block bodies for damage.

Check to make sure that the latch is not damaged or bent and that it operates properly with sufficient spring pressure to keep the latch tightly against the tip of the hook and allow the latch to spring back to the tip when released. If the latch does not operate properly, it should be replaced.

To Measure opening, depress latch against hook body as show.

Replace the hooks when opening is greater than 38mm.

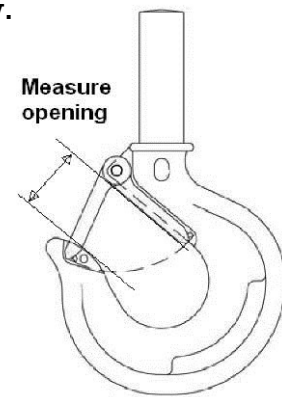

CHAIN

1. Clean chain with a non-caustic/non-acid type solvent and make a link by link inspection for nicks, gouges, twisted links, weld splatter, corrosion pits, striations, cracks in weld areas, wear and stretching. Chain with any one of these defects must be replaced.
2. Slack the portion of the chain that normally passes over the liftwheel. Examine the interlink area for the point of maximum wear. Measure and record the stock diameter at this point of the link. Then measure stock diameter in the same area on a link that does not pass over the liftwheel and compare these two measurements.

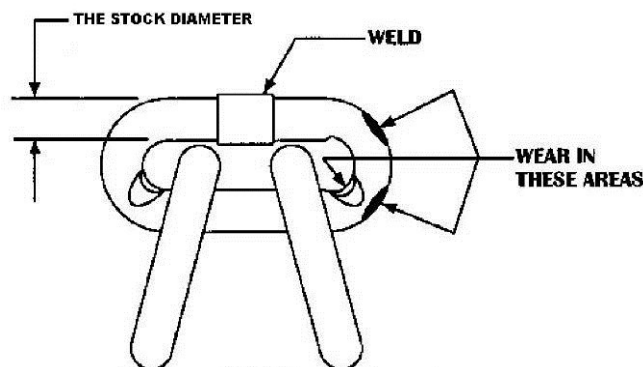

3. Also check chain for stretch using a larger caliper as show below to measure the outside length of a convenient number of links about 11(pitches). Measure the same number of links in a used section of chain and calculate the percentage increase in length of the worn chain.

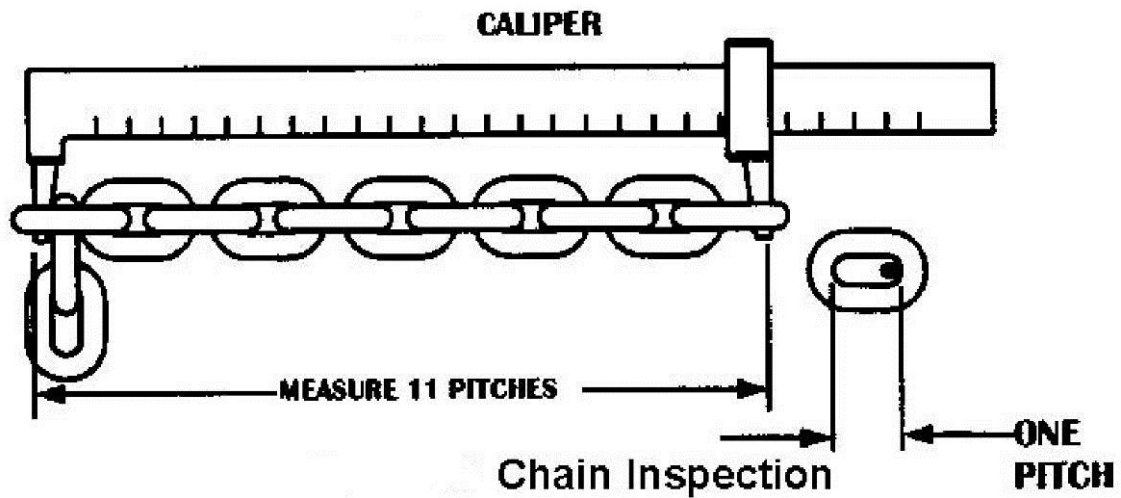

4. Chain is to be kept clean and lubricated. Visually check chain every time chain hoist is used. As oil needs to sit at the bearing surface of each chain link, it is advised to submerge the chain in oil for 30 min. Take it out and let the chain hang dripping for 24 hours before putting in the hoist.

 CAUTION
The chain used on this lifting motor has very carefully controlled dimensions and has been heat treated. Do not attempt to substitute any other manufacturer's chain.

Note: In the entertainment industry chain wear in general is only very limited, and often even impossible to measure after 10 years of normal use. On the other hand it is a well known fact that the load chains in the entertainment do tend to be misused or even abused and sometimes badly neglected in corrosion prevention. Severely damaged, deformed, dented, partly eaten or even broken chain links have been regularly reported by use in the entertainment sector, and constant attention must be given that such chains are immediately taken out of service. All this is typically the responsibility of the customer or user of the chain hoist.

IDENTIFICATION OF CHAIN:

FEC load chain can be recognized and determined original by the following marks on the chain

Chain specifications:

- diameter-7.1mm
- pitch-20.2mm
- grade-Grade80
- type of marking-see sample picture below. Every 15 links.
- minimum breaking strength-6300kgs
- weight per meter- 1.1kg/m

For replacement load chains use FEC chain only.

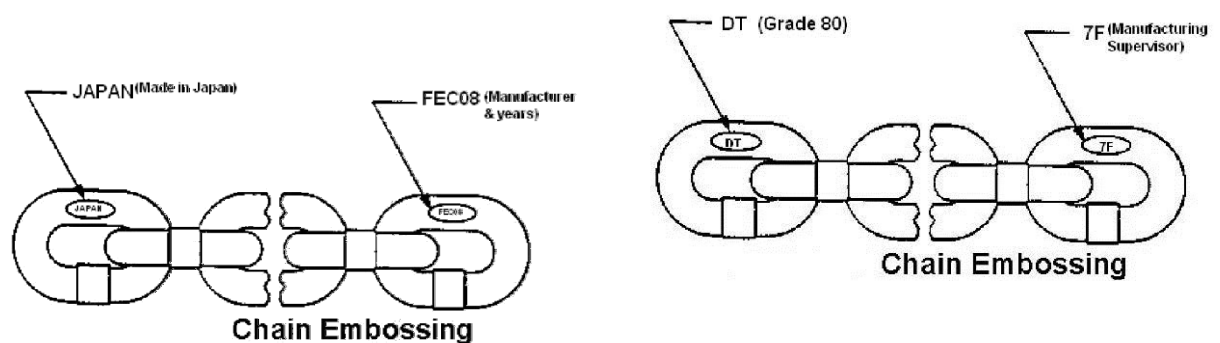

CHAIN REPLACEMENT WITH CHAIN IN LIFTING MOTOR

1. With the unit placing on workbench or motor up position, run the hook to its up limit.
 2. Remove the load block assembly from the old chain.
 3. Make a “C” link, attach the new chain to the load end of the old chain.
 4. Carefully jog the “UP” button and run the joined pieces of chain into the lifting motor until about 40cm of new chain comes out the other side.
 5. Remove the “C” link and the old chain. Remove the chain stop from the old chain by a hex head screwdriver.
 6. Attach the chain stop to the slack end of the new chain by capturing the 12th link with the two stop halves. Be sure there are no twists in the chain.
 7. Attach the load block on new chain by a hex head screwdriver.
- Make a “C” link



CHAIN REPLACEMENT WITH NO CHAIN IN CHAIN HOIST

1. With the unit placing on workbench, run the hook to its up limit.
2. Remove the load block assembly from the old chain.
3. Remove the chain stop from the old chain.
4. Carefully jog the “UP” button and detach the old chain out of the lifting motor.
5. Insert the new chain into the load sheave.
6. Feed the new chain into the chain hoist by jogging the “DOWN” button.
7. Allow about 40cm of chain below the chain hoist on the slack end.
8. Attached the chain stop and load block assembly. Be sure there are no twists in the chain.



CHAIN END STOP

The end stop on the dead-end chain should be mounted on the 11th link. (No less than 11 links should be in between the dead-end and the chain stop).

CUTTING CHAINS

FEC load chain is hardened and therefore difficult to cut. The following methods are recommended when cutting a length of new chain from stock or cutting worn chain.

- a) Use a grinder and nick the link on both sides, then secure the link in a vise and break of with a hammer.



Cutting chain by Nicking

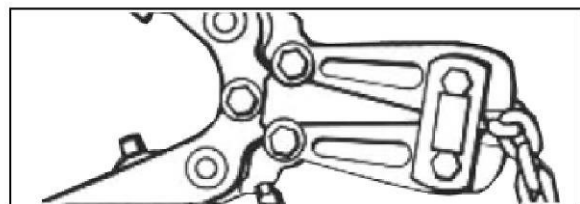

- b) Use a bolt cutter with special cutter jaws for cutting hardened chain.

Cutting chain with a Bolt Cutter

LOAD CHAIN CLEANING

Clean the load chain with acid-free solvent and coat with new ISO VG-320 or equivalent gear oil. Wipe excess Oil to prevent dripping. Never apply grease to the chain.

OVERLOAD LIMITING CLUTCH

The parts of limiting clutch are mounted free on the gear input shaft. The adjustable slip clutch, fitted as an overload safety device. This device has been calibrated at the factory and is engineered for low maintenance and also serve as an overload protection.

Hook a load of 1.25 times the nominal load into the hoist.

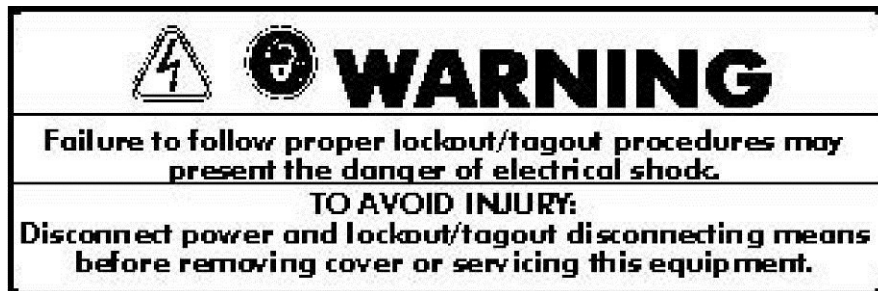

SIGNS OF INADEQUATE ELECTRICAL POWER:

The hoist must be supplied with adequate electrical power in order to operate properly. The signs of low voltage are:

- Noisy hoist operation due to brake and /or chattering.
- Dimming of lights or slowing of motors connected to the same circuit.
- Heating of the hoist motor and other internal components as well as heating of the wires and connectors in the circuit feeding the hoists.
- Failure of the hoist to lift the load due to motor stalling.

7-2 Troubleshooting

If the winch fails to start after several attempts or the hoist's operation appears to be defective check the following:

TROUBLE SHOOTING FOR CHAIN HOIST		
Trouble	Probable Cause	Check and Remedy
1. Lifting motor does not respond to pushbutton	A) Power failure in supply line	A) Check circuit, breakers, switch and connection in power supply line
	B) Wrong voltage or frequency	B) Check voltage and frequency of power supply against the rating on the nameplate of the motor.
	C) Improper connections in chain hoist of push button	C) Check all connections at line connectors and on terminal block.
	D) Brake does not release	D) Check brake coil connection for open or short circuit. Check wiring for relay rectifier.
2. Hook does not stop promptly	A) Chain hoist overloaded	A) Reduce load within rated capacity of chain hoist.
	B) Brake not holding	B) Check brake and it may be necessary to replace discs.
3. Hook moves in wrong direction	A) Improper connection	A) Check all connections against wiring diagram.
4. Chain hoist hesitates to lift when energized	A) Chain hoist overloaded	A) Reduce load within rated capacity of chain hoist.
	B) Worn overload limiting clutch	B) Check and adjust limiting clutch
	C) Low voltage	C) Determine cause of low voltage and bring up to within plus or minus 10% of the voltage specified on the motor. Measure voltage at the lifting motor in terminal block power input.
5. Hook raises but will not lower	A) "Down" circuit open	A) Check circuit for loose connections.
	B) Broken conductor in pushbutton cable	B) Check each conductor in the cable. If one is broken, reduce entire cable.

6. Hook lowers but will not raise	A) Lifting motor overload	A) Reduce load to within rated capacity of chain hoist.
	B) Low voltage	B) Determine cause of low voltage and bring up to within plus or minus 10% of the voltage specified on the motor. Measure voltage at the lifting motor in terminal block power input.
	C) "UP" circuit open	C) Check circuit for loose connections
	D) Broken conductor in pushbutton cable	D) Check each conductor in the cable. If one is broken, replace entire cable.
	E) Worn overload limiting clutch	E) Adjust or replace overload clutch assembly.
	F) Loose screw clamps	F) Ensure that screw clamps are tightened on the terminal blocks.
7. Motor overheats	A) Excessive load	A) Reduce load to within rated capacity of chain hoist
	B) Low voltage	B) Determine cause of low voltage and bring up to within plus or minus 10% of the voltage specified on the motor. Measure voltage at the lifting motor in terminal block power input.
	C) Frequent starting or reversing	C) Excessive inching, jogging or reversing should be avoided since this type of operation will drastically shorten the life of motor and brake.
	D) Brake dragging	D) Replace brake assembly
8. Lack of proper lifting speed	A) Chain hoist overload	A) Reduce load to within rated capacity of chain hoist
	B) Brake dragging	B) Replace brake assembly
	C) Low voltage	C) Determine cause of low voltage and bring up to within plus or minus 10% of the voltage specified on the motor. Measure voltage at the lifting motor in terminal block power input.
	D) Overload limiting clutch intermittently slipping	D) Adjust or replace overload limiting clutch assembly.

9. Motor brake noise or chatter (while starting chain hoist)	A) Brake needs replacement	A) Replace brake assembly
	B) Low voltage	B) Determine cause of low voltage and bring up to within plus or minus 10% of the voltage specified on the motor. Measure voltage at the lifting motor in terminal block power input.
10. Motor brake “buzz” (anytime chain hoist is running)	A) Brake needs replacement B) Broken brake coil	A) Replace brake assembly
		B) Replace the brake coil and check the relay rectifier.

NB: All mechanical or electrical work must be carried out by a qualified tradesperson

8. Drawings and Parts List

8-1 Assembly drawings and part list

MODEL: DU-903 - Assembly Drawing

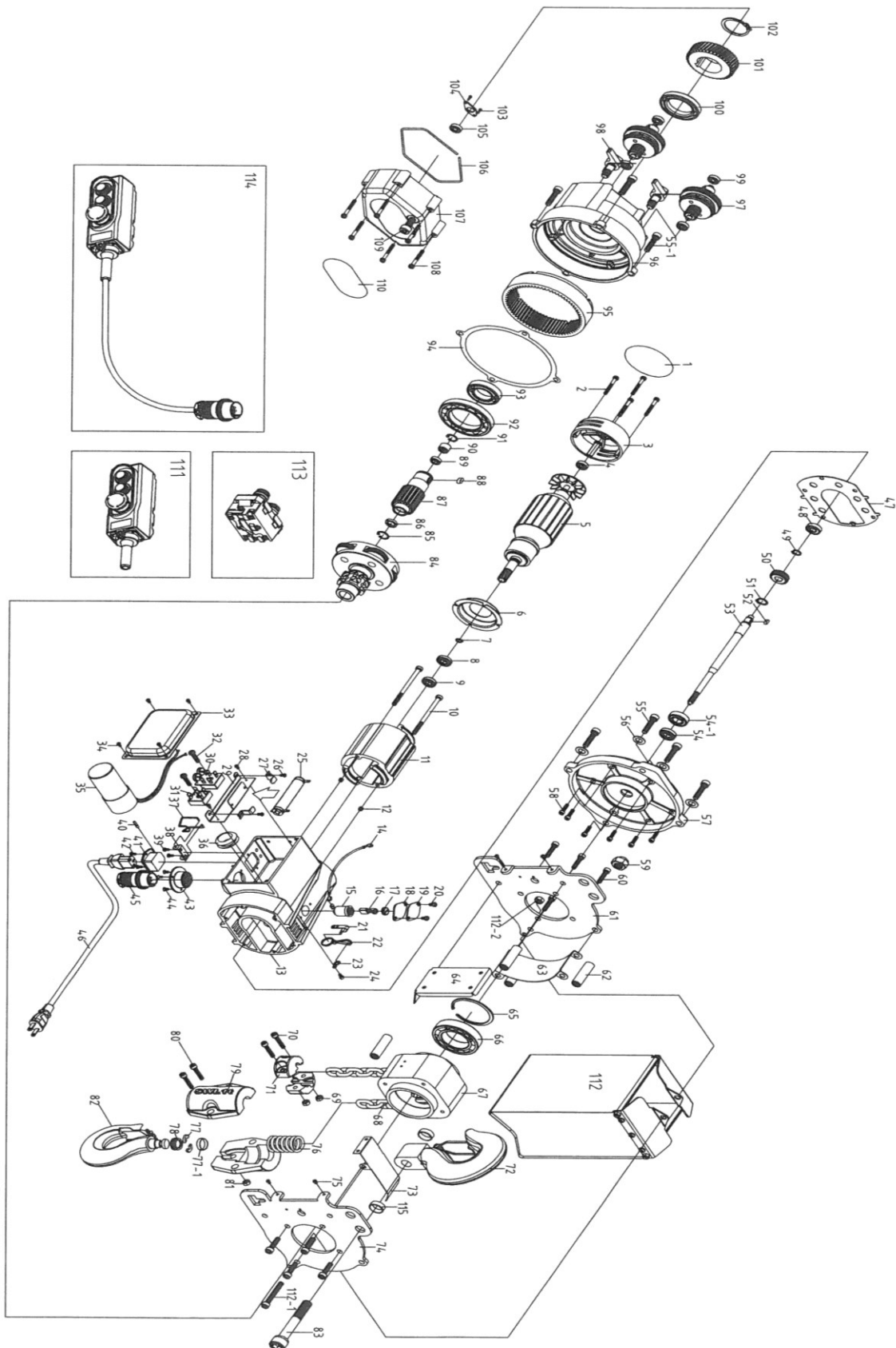

MODEL: DU-903 - Parts List

1	NAMEPLATE 1	49	FIXING SPRING	95	GEAR RING
2	BOLT	50	GEAR	96	GEAR HOUSING
3	MOTOR COVER	51	FIXING SPRING	97	GEAR BRAKE SET
4	BEARING	52	FIRST SECTION GEAR SHAFT	98	BRAKE PAWL SET
5	ROTOR	53	KEY	99	BEARING
6	AIR GUIDING IRON COVER	54	OIL SEAL	100	OIL SEAL
7	SNAP RING	55	SCREW	101	GEAR
8	BEARING	55-1	BOLT	102	SNAP RING
9	OIL SEAL	56	WASHER	103	SCREW
10	BOLT	57	GEAR COVR	104	BEARING STOPPING SHEET
11	STATOR	58	SCREW	105	BEARING
12	SCREW	59	NUT	106	GASKET
13	MAIN BODY BASE	60	SCREW	107	FIRST LAYER GEAR BOX
14	CABLE	61	LEFT MAIN BODY SHEET	108	BOLT
15	BASE OF CARBON BRUSH	62	FIX ROD OF MAIN BODY	109	BOLT
16	CARBON BRUSH	63	MAIN BODY COVER 1	110	NAMEPLATE 2
17	CARBON BRUSH COVER	64	MAIN BODY COVER 2	111	SWITCH WITHOUT CABLE
18	CARBON BRUSH SET PROTECTION	65	SNAP RING	112	CHAINBAG
19	CARBON BRUSH SET PROTECTION	66	BEARING	112-1	BOLT
20	SCREW	67	CHAIN SHEAVE	112-2	NUT
21	BINDER OF CABLE	68	LOAD CHAIN	113	SWITCH CONTACTOR
22	LANYARD CLIP	69	NUT	114	SWITCH SET WITH CABLE
23	TWIN-CIRCLE TYPE HOOK	70	SCREW	115	BUSHER
24	SCREW	71	CHAIN STOPPED BLOCK		
25	RESISTOR	72	UPPER HOOK		
26	SCREW	73	MAIN BODY COVER 3		
27	FIX PIN	74	RIGHT MAIN BODY SHEET		
28	SCREW	75	SCREW		
29	FIX PLATE	76	LIMIT SPRING		
30	REGULATOR W/ VARISTOR	77	LOWER HOOK COMPONENT 1		
31	REGULATOR	77-1	LOWER HOOK COMPONENT 2		
32	SCREW	78	BEARING		
33	ELECTRIC BOX COVER	79	LOWER HOOK SUSPENSION		
34	SCREW	80	SCREW		
35	CAPACITOR	81	NUT		
36	PLASTIC TUBE	82	LOWER HOOK		
37	CABLE HANGER	83	BOLT		
38	FIX PLATE	84	CHAIN GUIDER		
39	SCREW	85	SNAP RING		
40	FUSE	86	OIL SEAL		
41	POWER CONNECTOR SOCKET	87	THIRD SECTION GEAR SHAFT		
42	SCREW	88	KEY		
43	SWITCH CONNECTOR SOCKET	89	OIL SEAL		
44	SCREW	90	BEARING		
45	SWITCH CONNECTOR	91	SNAP RING		
46	POWER CABLE SET	92	BEARING		
47	GASKET	93	BEARING		
48	BEARING	94	GASKET		

MODEL: DU-904 - Assembly Drawing

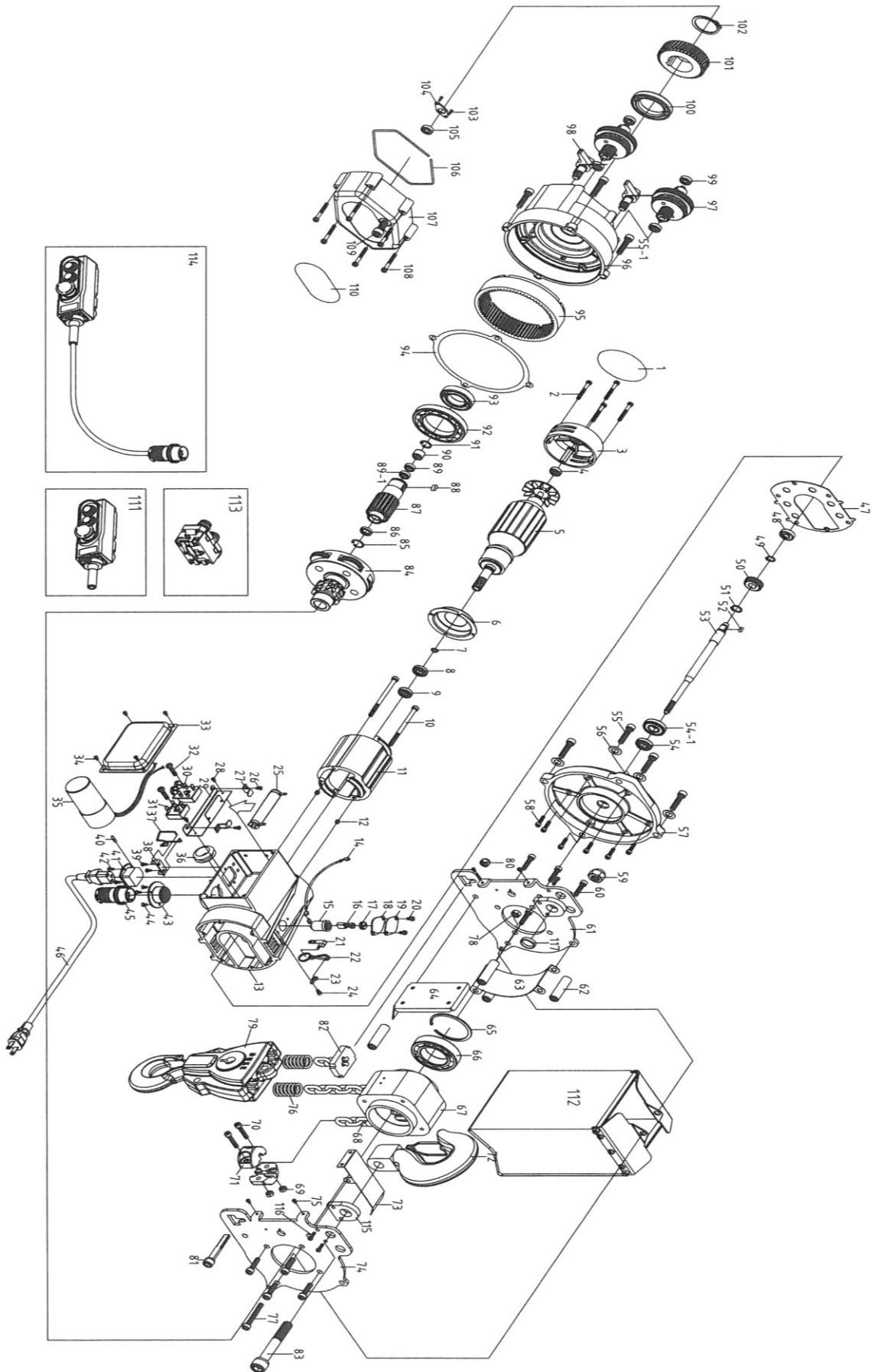

MODEL: DU-904 - Parts List

1	NAMEPLATE 1	41	POWER CONNECTOR SOCKET	80	NUT
2	BOLT	42	SCREW	81	BOLT
3	MOTOR COVER	43	SWITCH CONNECTOR SOCKET	82	CROSS TYPE SHEET
4	BEARING	44	SCREW	83	BOLT
5	ROTOR	45	SWITCH CONNECTOR	84	CHAIN GUIDER
6	AIR GUIDING IRON COVER	46	POWER CABLE SET	85	SNAP RING
7	SNAP RING	47	GASKET	86	OIL SEAL
8	BEARING	48	BEARING	87	THIRD SECTION GEAR SHAFT
9	OIL SEAL	49	FIXING SPRING	89	OIL SEAL
10	BOLT	50	GEAR	90	BEARING
11	STATOR	51	FIXING SPRING	91	SNAP RING
12	SCREW	52	FIRST SECTION GEAR SHAFT	92	BEARING
13	MAIN BODY BASE	53	KEY	93	BEARING
14	CABLE	54	OIL SEAL	94	GASKET
15	BASE OF CARBON BRUSH	55	SCREW	95	GEAR RING
16	CARBON BRUSH	55-1	BOLT	96	GEAR HOUSING
17	CARBON BRUSH COVER	56	WASHER	97	GEAR BRAKE SET
18	CARBON BRUSH SET PROTECTION	57	GEAR COVR	98	BRAKE PAWL SET
19	CARBON BRUSH SET PROTECTION	58	SCREW	99	BEARING
20	SCREW	59	NUT	100	OIL SEAL
21	BINDER OF CABLE	60	SCREW	101	GEAR
22	LANYARD CLIP	61	LEFT MAIN BODY SHEET	102	SNAP RING
23	TWIN-CIRCLE TYPE HOOK	62	FIX ROD OF MAIN BODY	103	SCREW
24	SCREW	63	MAIN BODY COVER 1	104	BEARING STOPPING SHEET
25	RESISTOR	64	MAIN BODY COVER 2	105	BEARING
26	SCREW	65	SNAP RING	106	GASKET
27	FIX PIN	66	BEARING	107	FIRST LAYER GEAR BOX
28	SCREW	67	CHAIN SHEAVE	108	BOLT
29	FIX PLATE	68	LOAD CHAIN	109	BOLT
30	REGULATOR W/ VARISTOR	69	NUT	110	NAMEPLATE 2
31	REGULATOR	70	SCREW	111	SWITCH WITHOUT CABLE
32	SCREW	71	CHAIN STOPPED BLOCK	112	CHAINBAG
33	ELECTRIC BOX COVER	72	UPPER HOOK	113	SWITCH CONTACTOR
34	SCREW	73	MAIN BODY COVER 3	114	SWITCH SET WITH CABLE
35	CAPACITOR	74	RIGHT MAIN BODY SHEET	115	BOLSTER PLATE
36	PLASTIC TUBE	75	SCREW	116	SCREW
37	CABLE HANGER	76	LIMIT SPRING	117	BUSHER
38	FIX PLATE	77	BOLT		
39	SCREW	78	NUT		
40	FUSE	79	LOWER HOOK SET		

8-2 Electrical system drawings and part list

MODEL: DU-903/DU-904 - Electrical System Drawings

CONTROL CIRCUIT

